

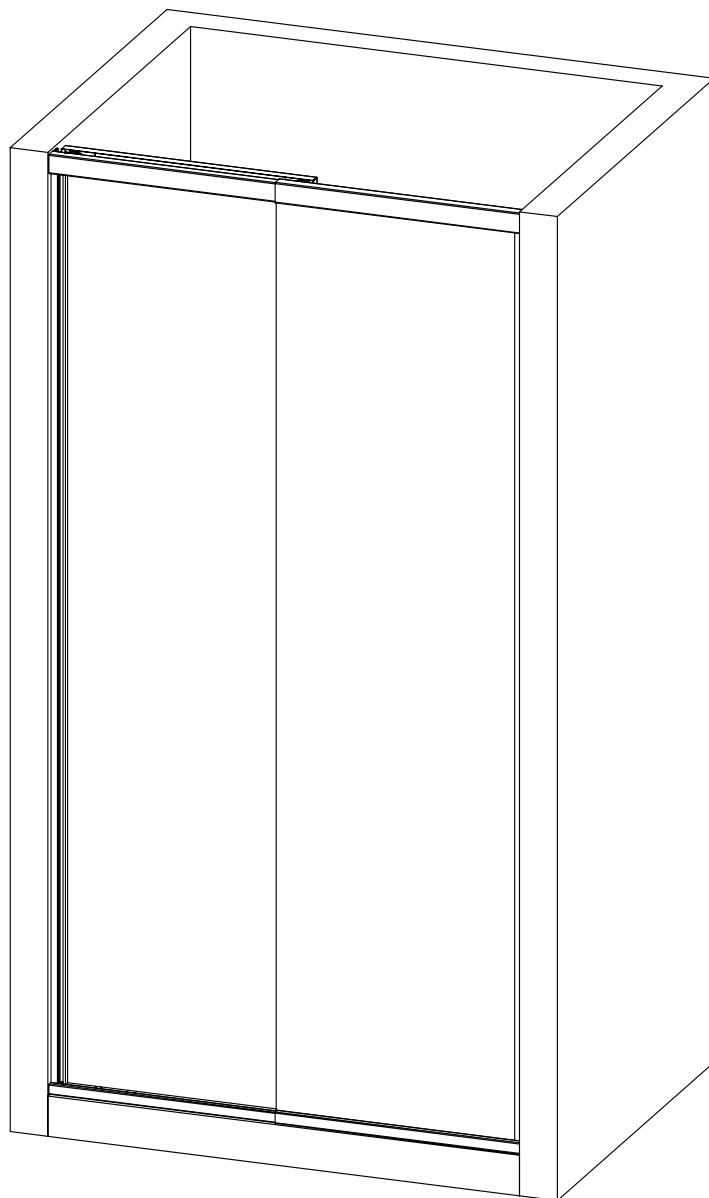

BIANCHI & FONTANA

MYLO MYA



MATERIALE CONTENUTO ALL'INTERNO DELL'IMBALLO COMPOSTO DA 2 SCATOLE:

1. ANTA SCORREVOLE
2. ANTA FISSA E PROFILI TELAIO CON SACCHETTO PER IL FISSAGGIO COMPOSTO DA 6 VITI CON TASSELLI

CONDIZIONI DI BASE

COMPENSAZIONE STANDARD FINO
ALL'ESTENSIONE MASSIMA DEL BOX

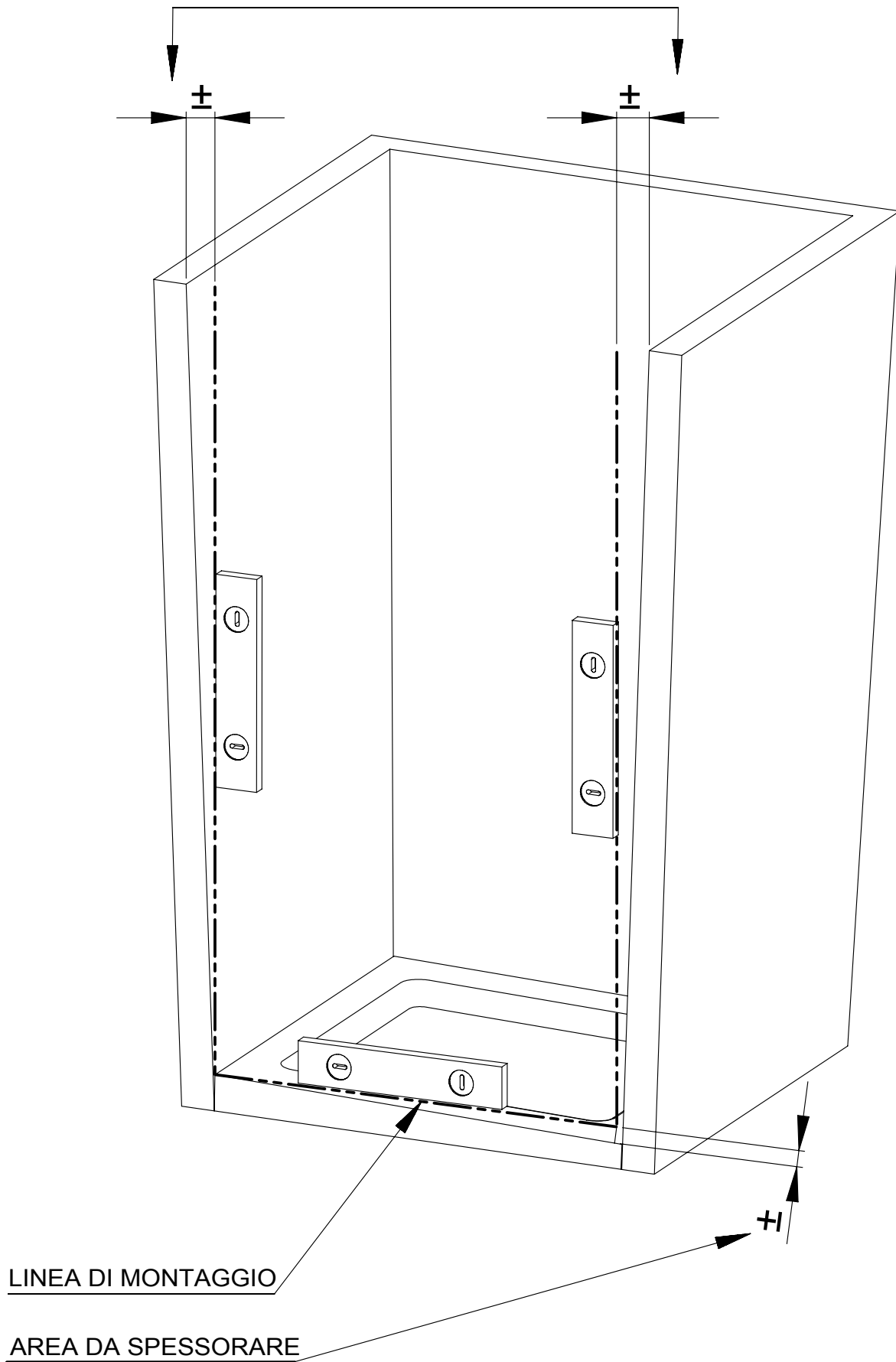

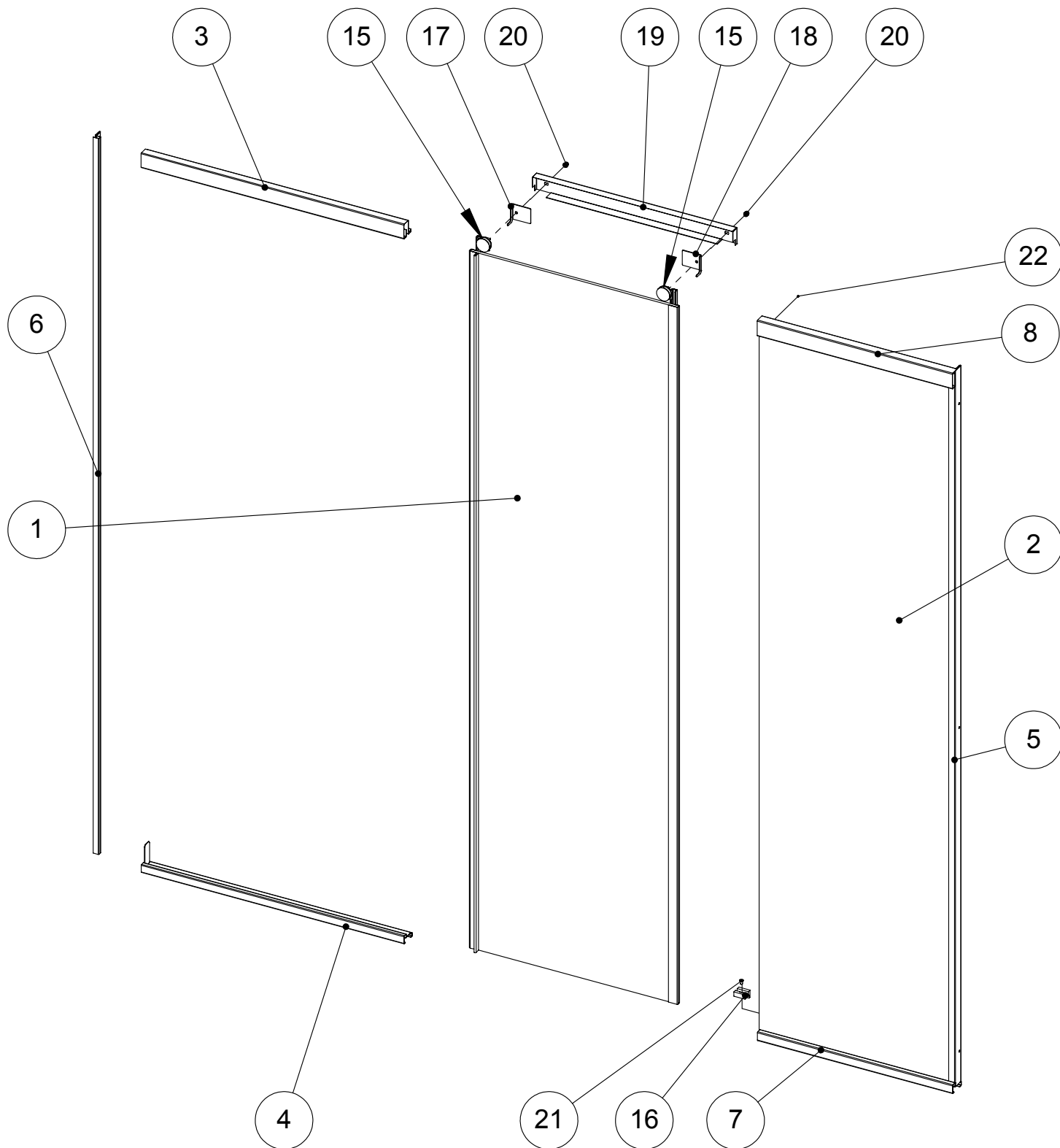

KIT MONTAGGIO DOTAZIONE



6 VITI INOX



6 TASSELLI Ø6

ATTREZZI NECESSARI

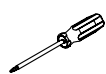

CACCIAVITE
A CROCE



CACCIAVITE
A TAGLIO

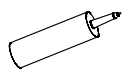

SILICONE

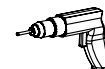

TRAPANO
(PUNTA Ø6)



MATITA

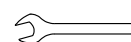

CHIAVE (ch.10)



METRO

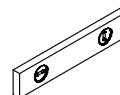

BOLLA

FASE 10

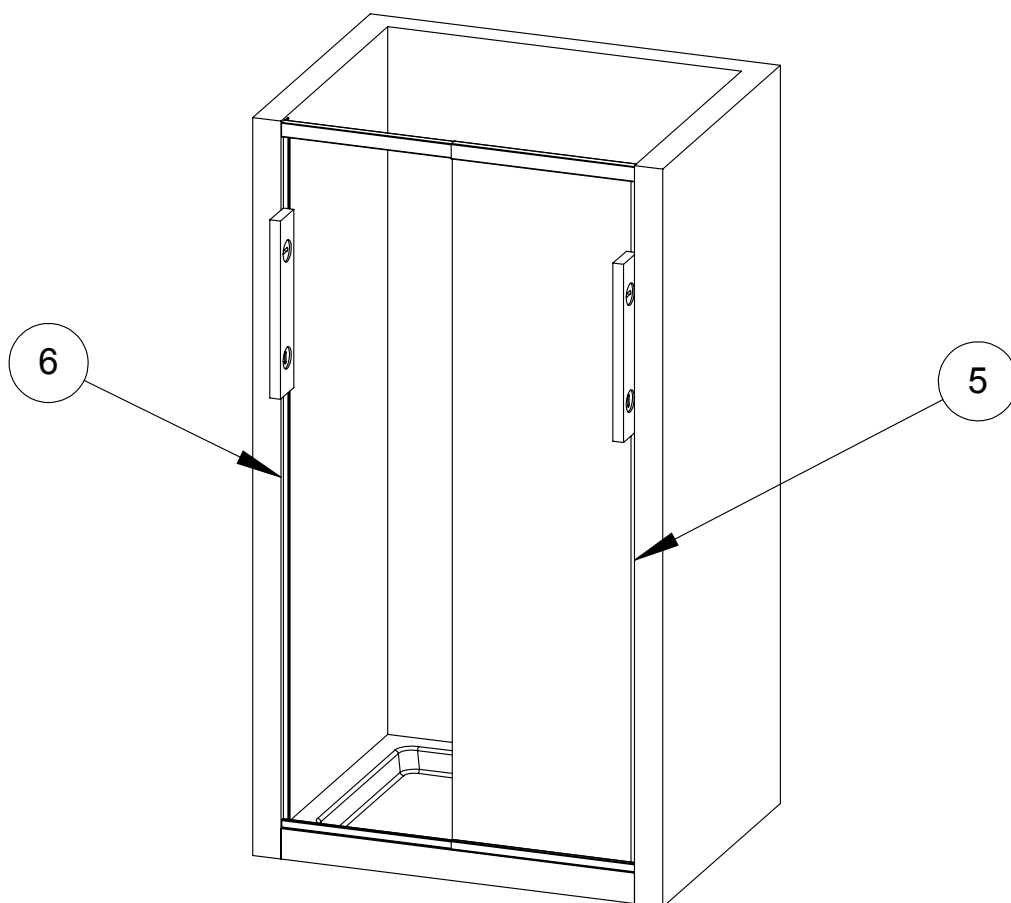

- (A) TOGLIERE LA PELLICOLA PROTETTIVA DAI PROFILI DELL'ANTA FISSA PRIMA DEL MONTAGGIO
- (B) PREASSEMBLARE LA STRUTTURA E INSERIRE IL BOX COMPLETO TRA LE DUE PARETI E IL PIATTO DOCCIA
- (C) POSIZIONARE I PROFILI (5) E (6) E UTILIZZARLI PER TRACCIARE LE FORATURE DI FISSAGGIO ALLA PARETE
- (D) ESEGUIRE I FORI PER I TASSELLI
- (E) INSERIRE I TASSELLI

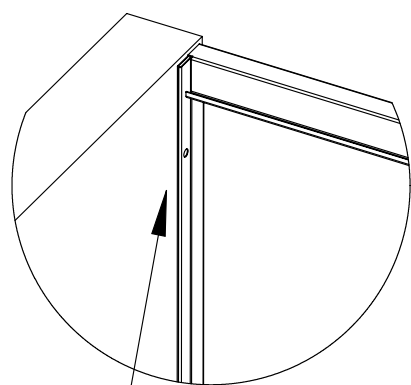

(C)



(D)



(E)

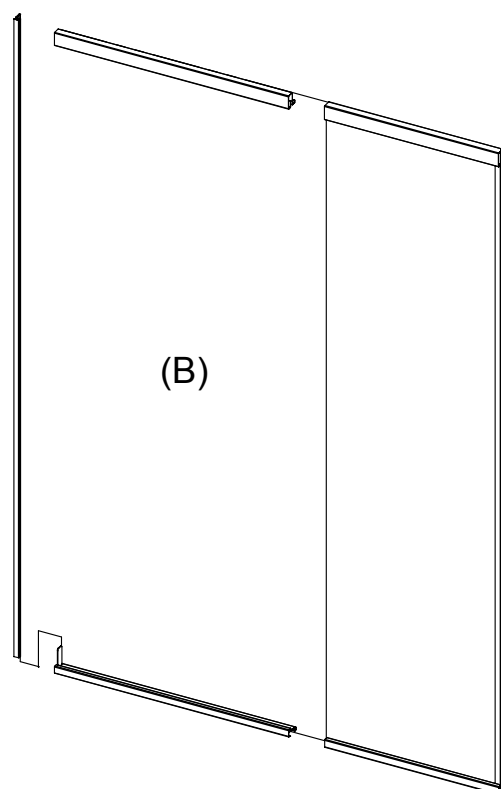

FASE 20

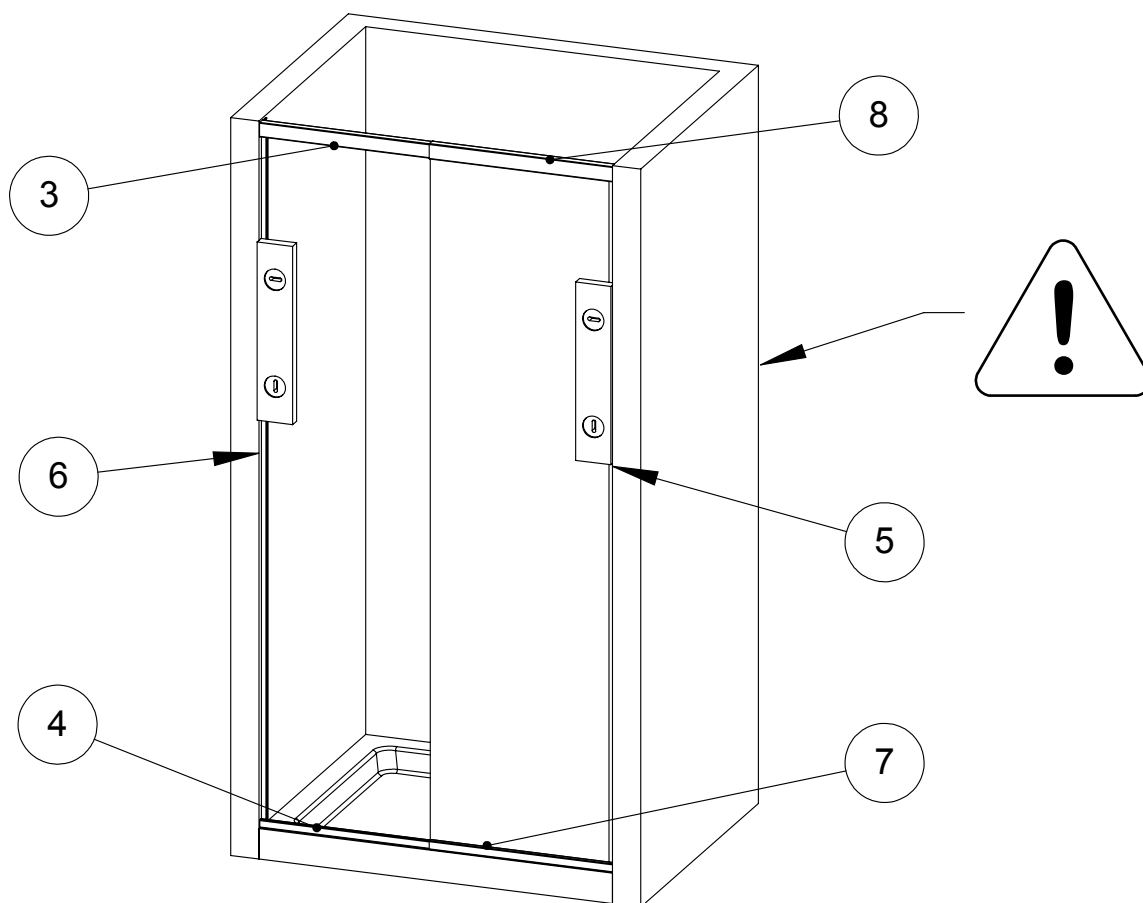

- (A) INSERIRE IL BOX COMPLETO ESCLUSA L'ANTA SCORREVOLE TRA LE DUE PARETI
- (B) REGOLARE L'ESTENSIBILITA' DEL BOX E BLOCCARE I PROFILI ESTENSIBILI INFERIORI CON LA VITE (21) E I PROFILI SUPERIORI CON LA VITE (22)
- (C) REGOLARE LA STRUTTURA E FISSARE I PROFILI (5) E (6) A MURO TRAMITE LE VITI CON TASSELLI

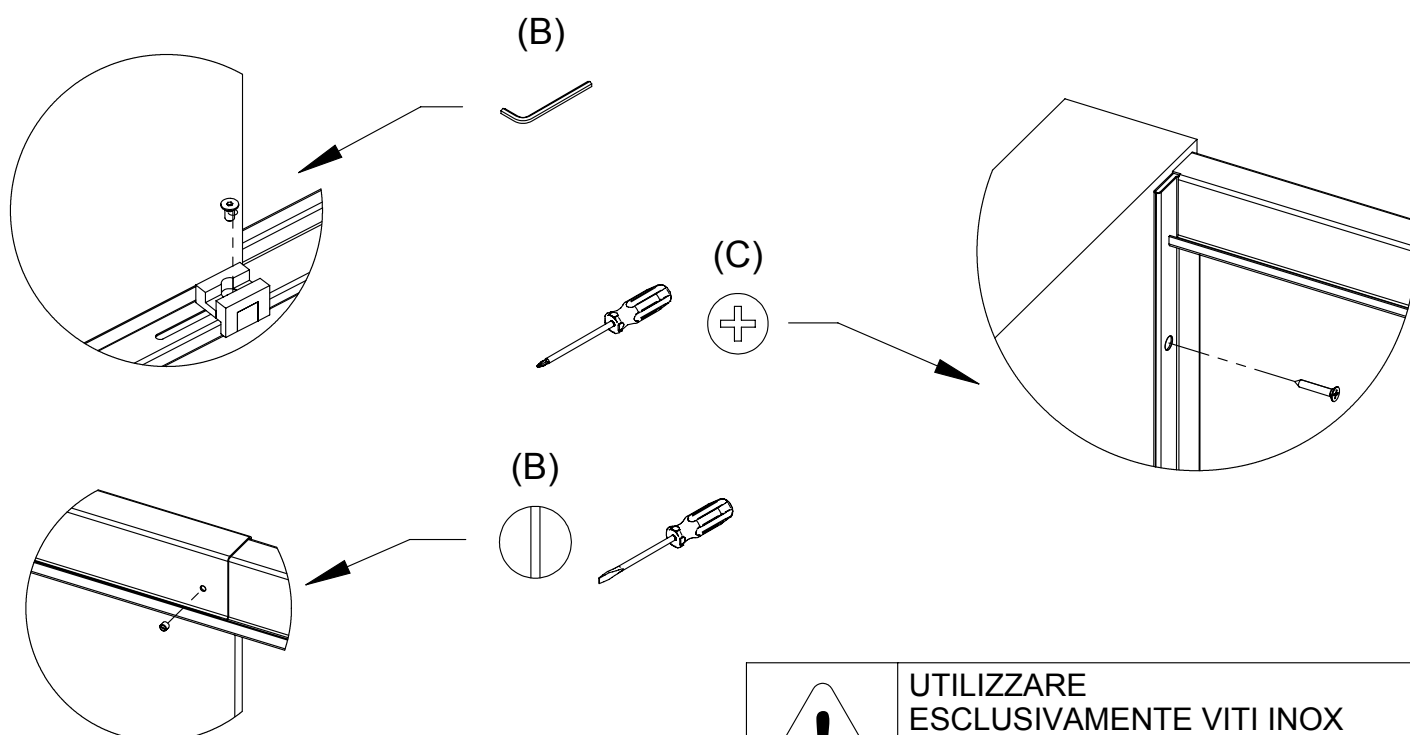

 **UTILIZZARE ESCLUSIVAMENTE VITI INOX**
il non utilizzo di viti inox può trasmettere la presenza di ruggine nella struttura

FASE 30

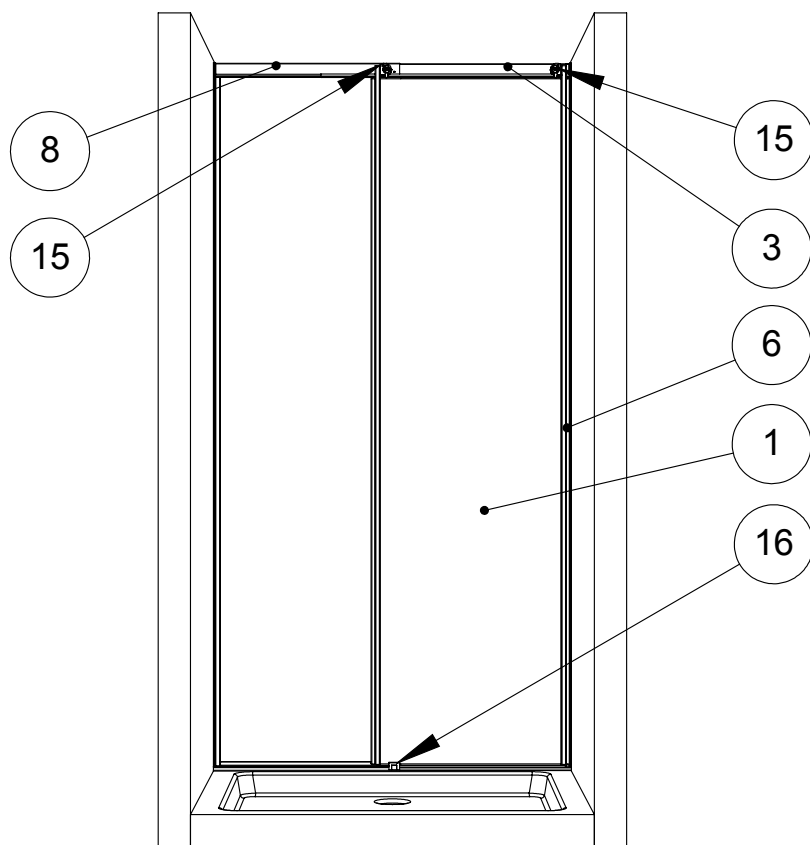

- (A) TOGLIERE LA PELLICOLA PROTETTIVA DAI PROFILI DELL'ANTA SCORREVOLE
- (B) APRIRE IL TASSELLO (16) PER FACILITARE L'INSERIMENTO DELL'ANTA SCORREVOLE
- (C) MONTARE L'ANTA SCORREVOLE (1) POSIZIONANDO LE RUOTE (15) NELL'APPOSITA GUIDA SUL PROFILO DI SCORRIMENTO (3 E 8)
- (D) RICHIUDERE IL TASSELLO DI GUIDA (16)
- (E) ACCOSTARE L'ANTA SCORREVOLE AL PROFILO (6) E REGOLARE GLI ECCENTRICI DELLE RUOTE AL FINE DI OTTENERE UNA CHIUSURA PERFETTA

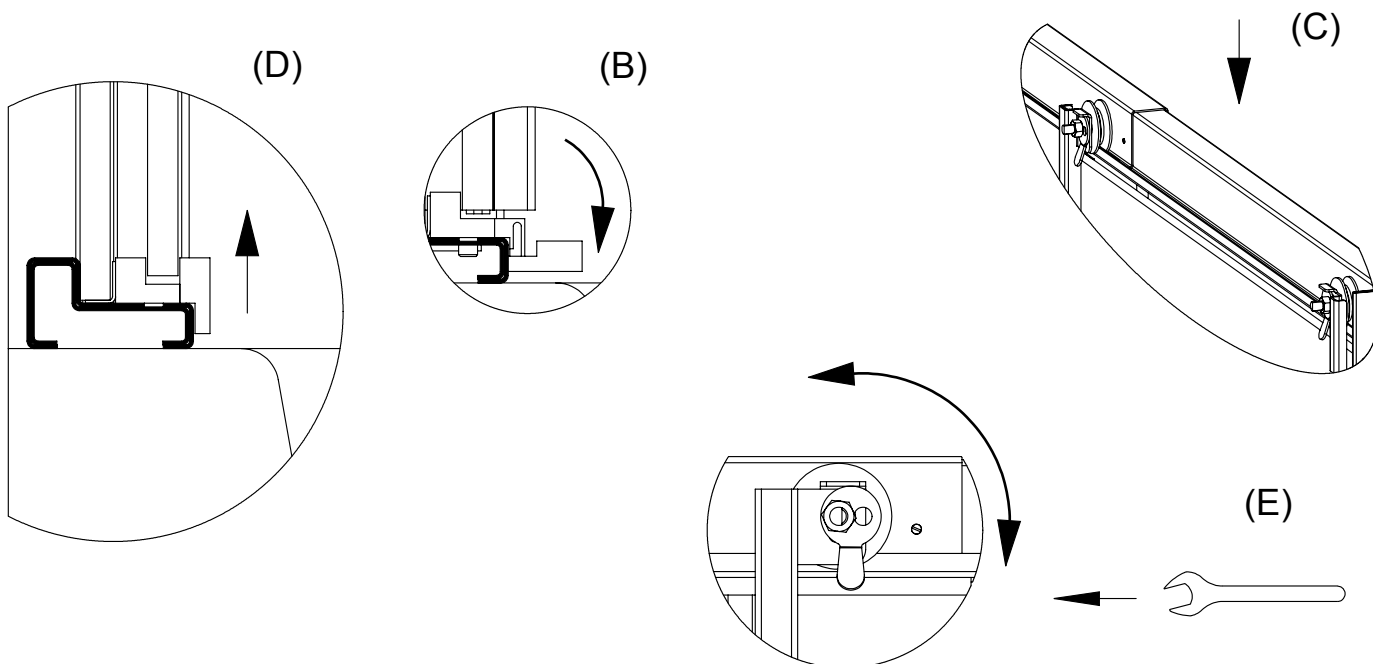

FASE 40

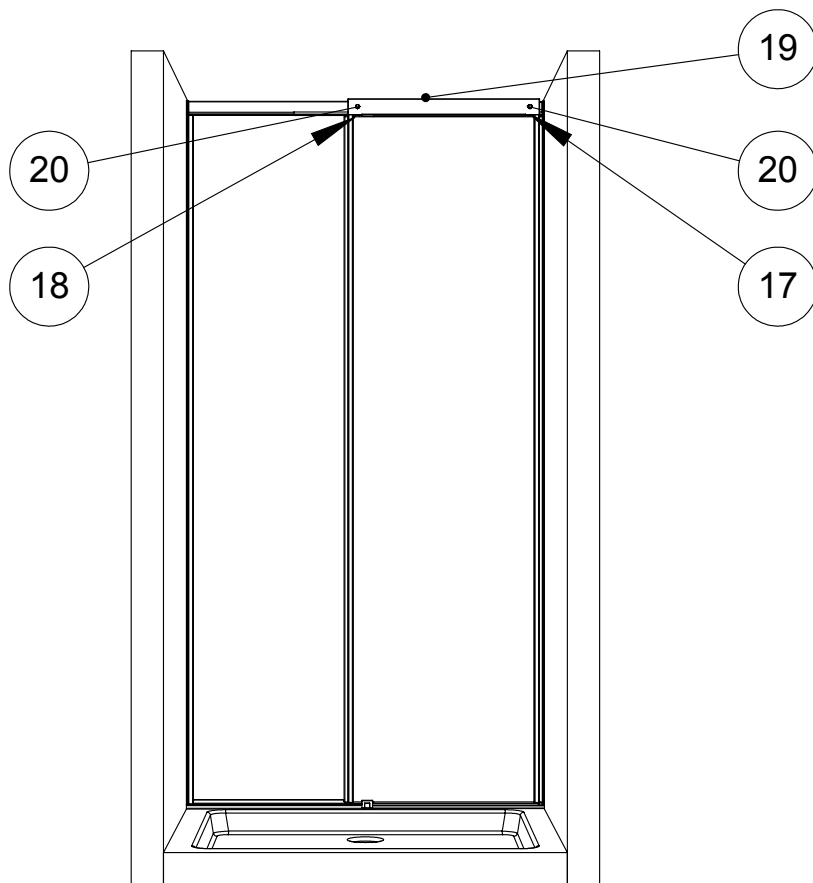

- (A) MONTARE I GANCI ANTI-SCARRUCOLAMENTO (17) E (18) SULLE RUOTE E CHIUDERE CON IL PROFILO DI COPERTURA (19) FISSANDOLO ALLE RUOTE CON I DADI ESAGONALI CHIUSI (20)

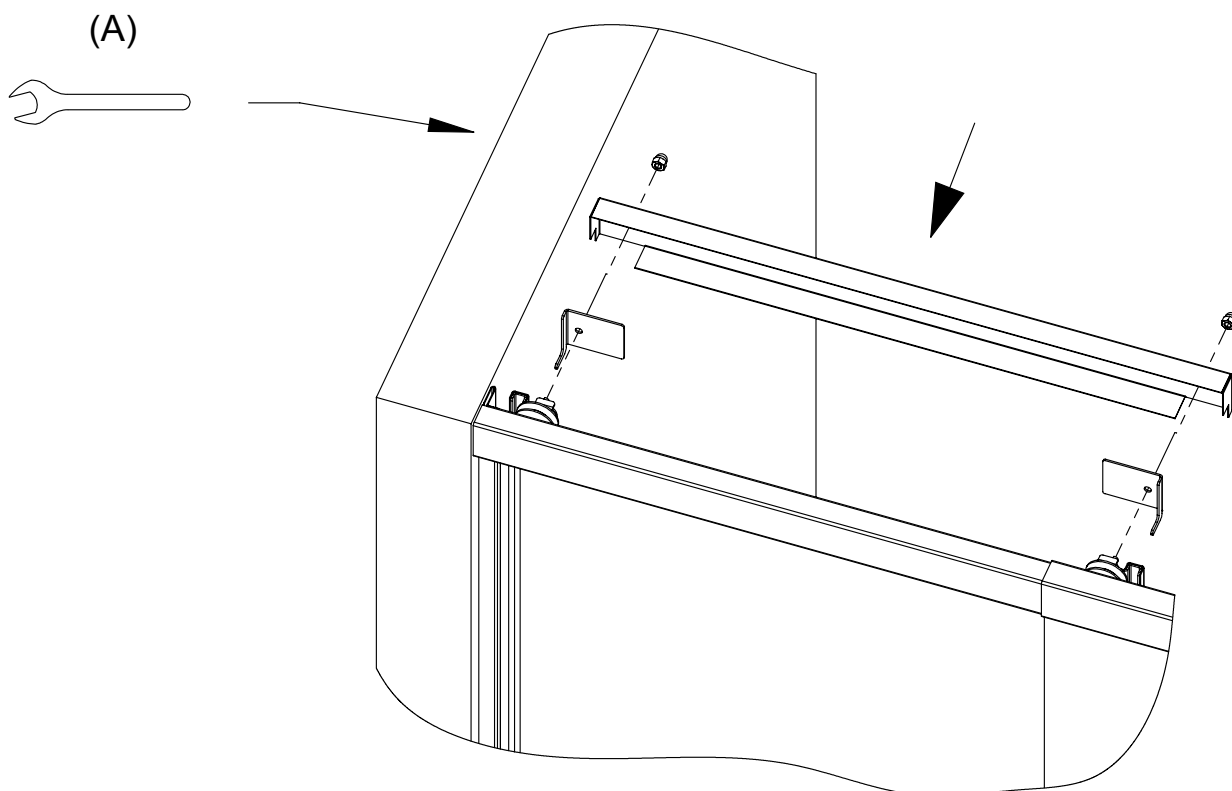

FASE 50

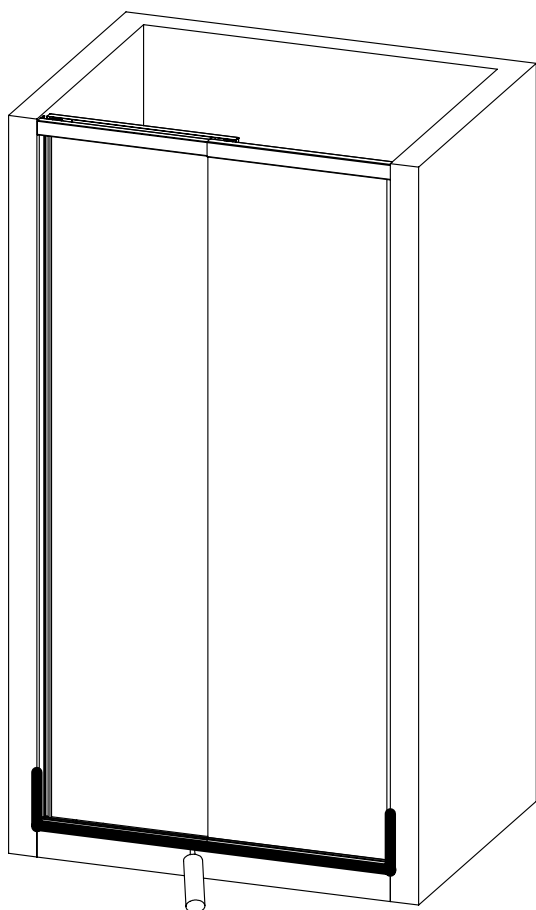

(A) SILICONARE NEL LATO ESTERNO I PROFILI (4) E (7)
SILICONARE NEL LATO ESTERNO I PROFILI (5) E (6) DI CIRCA 30 cm

(A)

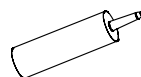

(B) SILICONARE NEL LATO INTERNO I PROFILI (5) E (6)



PER AVERE UNA PERFETTA TENUTA, MAI SILICONARE INTERNAMENTE I PROFILI (4) E (7) (BORDO PIATTO)

(B)

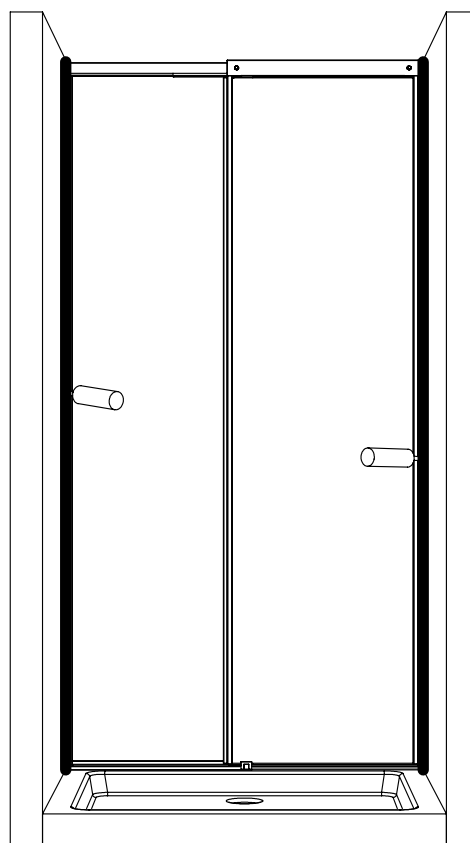
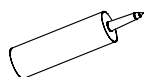

E' consigliabile utilizzare la cabina trascorso il periodo di asciugatura indicato dal sigillante utilizzato