

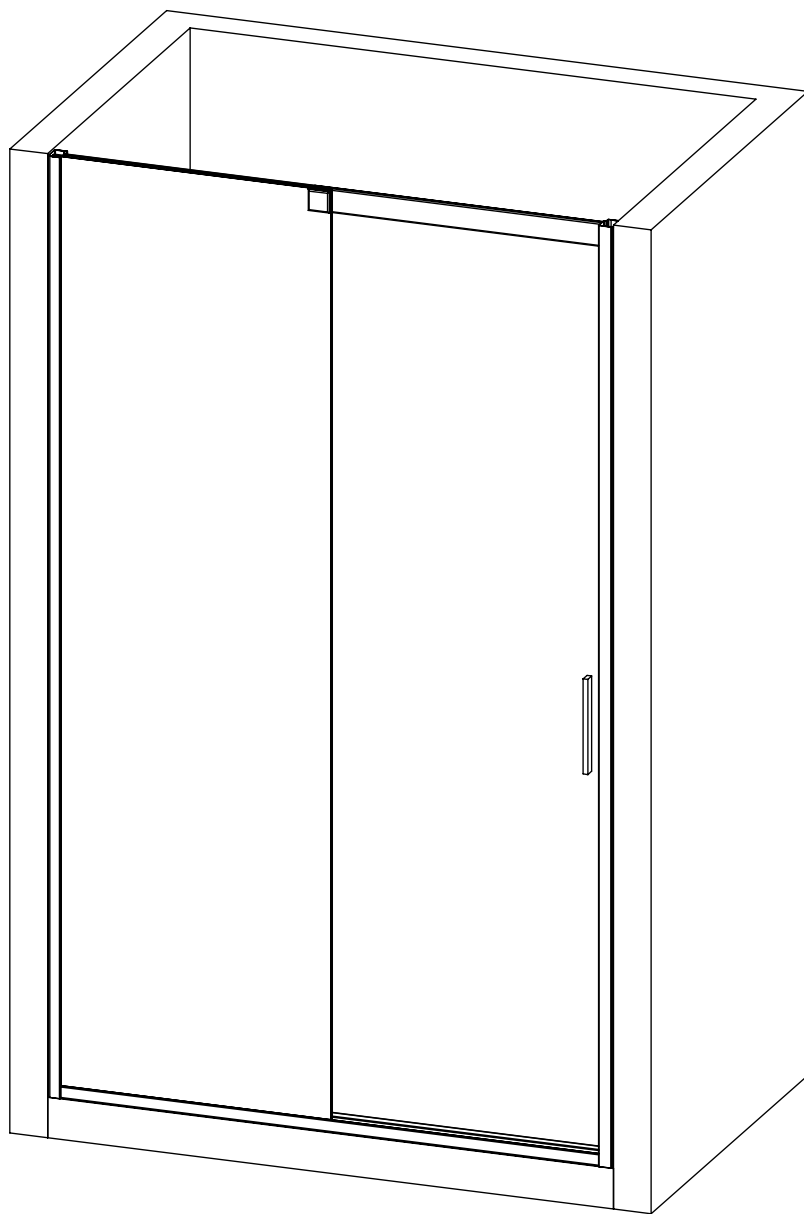

**BIANCHI & FONTANA**

**ZAKIA ZCA**



**MATERIALE CONTENUTO ALL'INTERNO DELL'IMBALLO COMPOSTO DA 2 SCATOLE:**

1. ANTA SCORREVOLE COMPLETA DI MANIGLIA
2. ANTA FISSA E PROFILI TELAIO CON SACCHETTO PER IL FISSAGGIO COMPOSTO DA 6 VITI CON TASSELLI

# CONDIZIONI DI BASE

COMPENSAZIONE STANDARD FINO  
ALL'ESTENSIONE MASSIMA DEL BOX

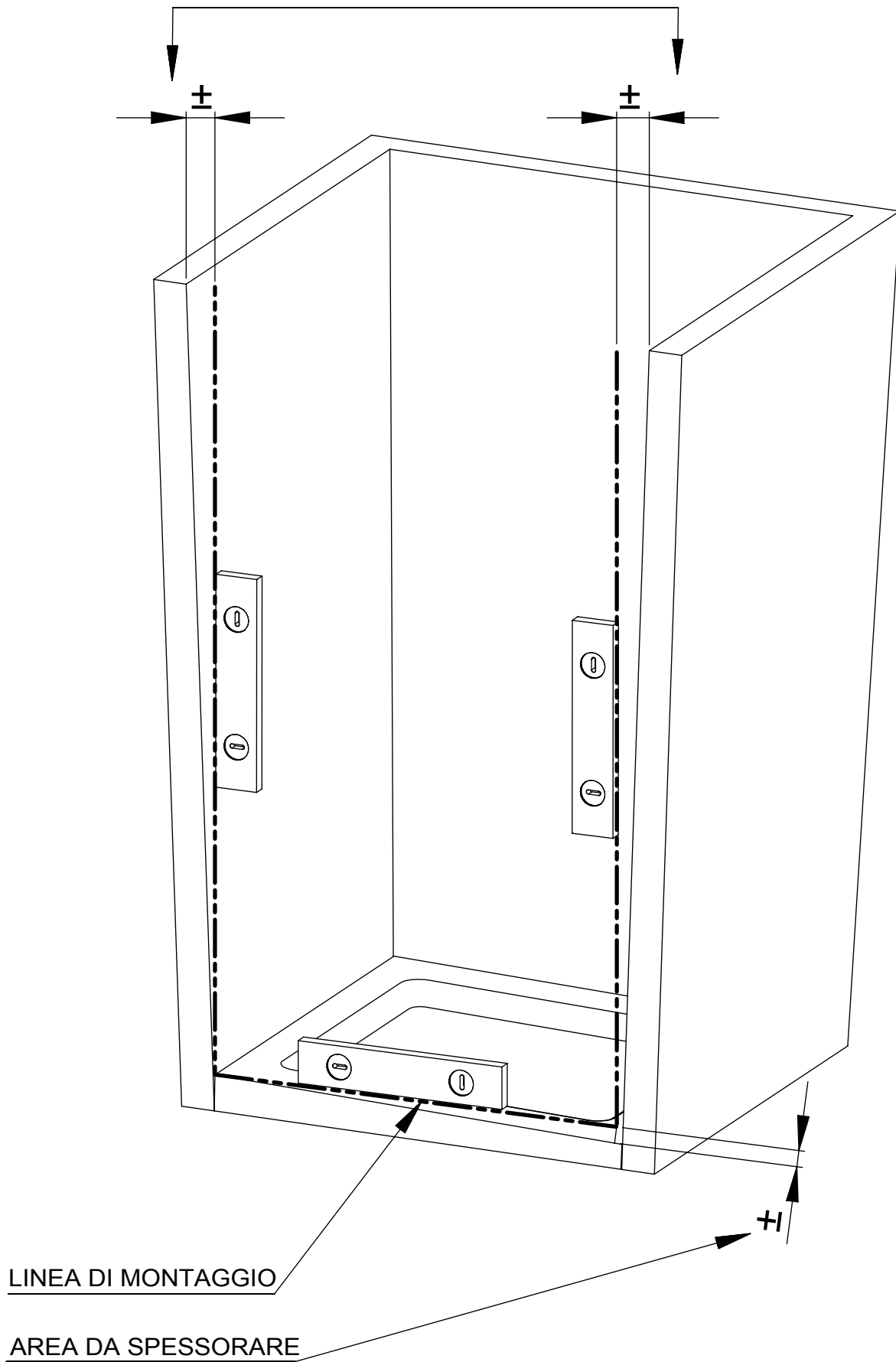

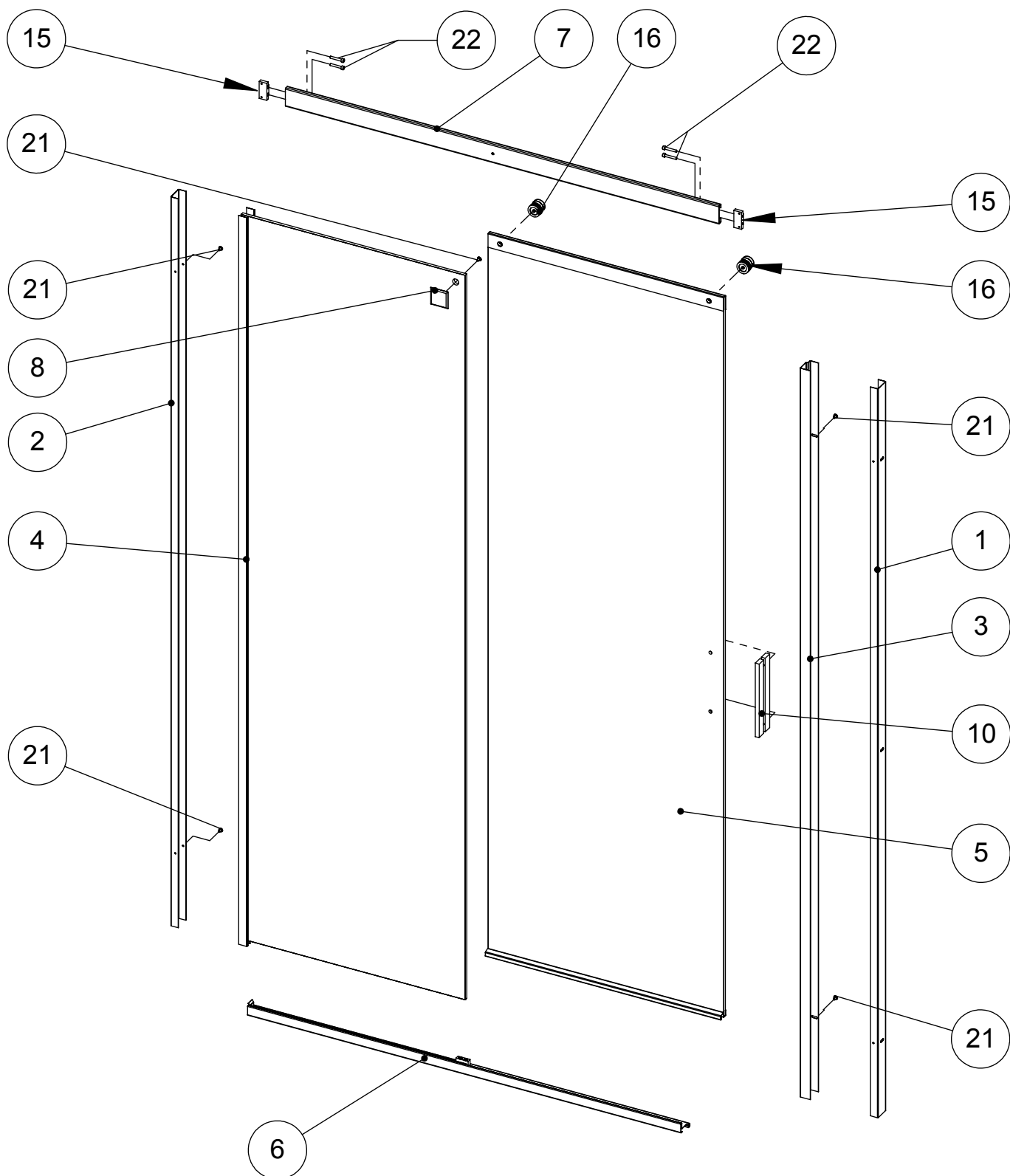

### KIT MONTAGGIO DOTAZIONE



6 VITI INOX



6 TASSELLI Ø6

### ATTREZZI NECESSARI

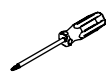

CACCIAVITE  
A CROCE

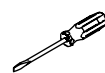

CACCIAVITE  
A TAGLIO

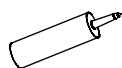

SILICONE

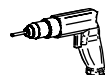

TRAPANO  
(PUNTA Ø6)



MATITA



BRUGOLA  
(ch.3)



METRO

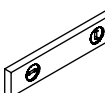

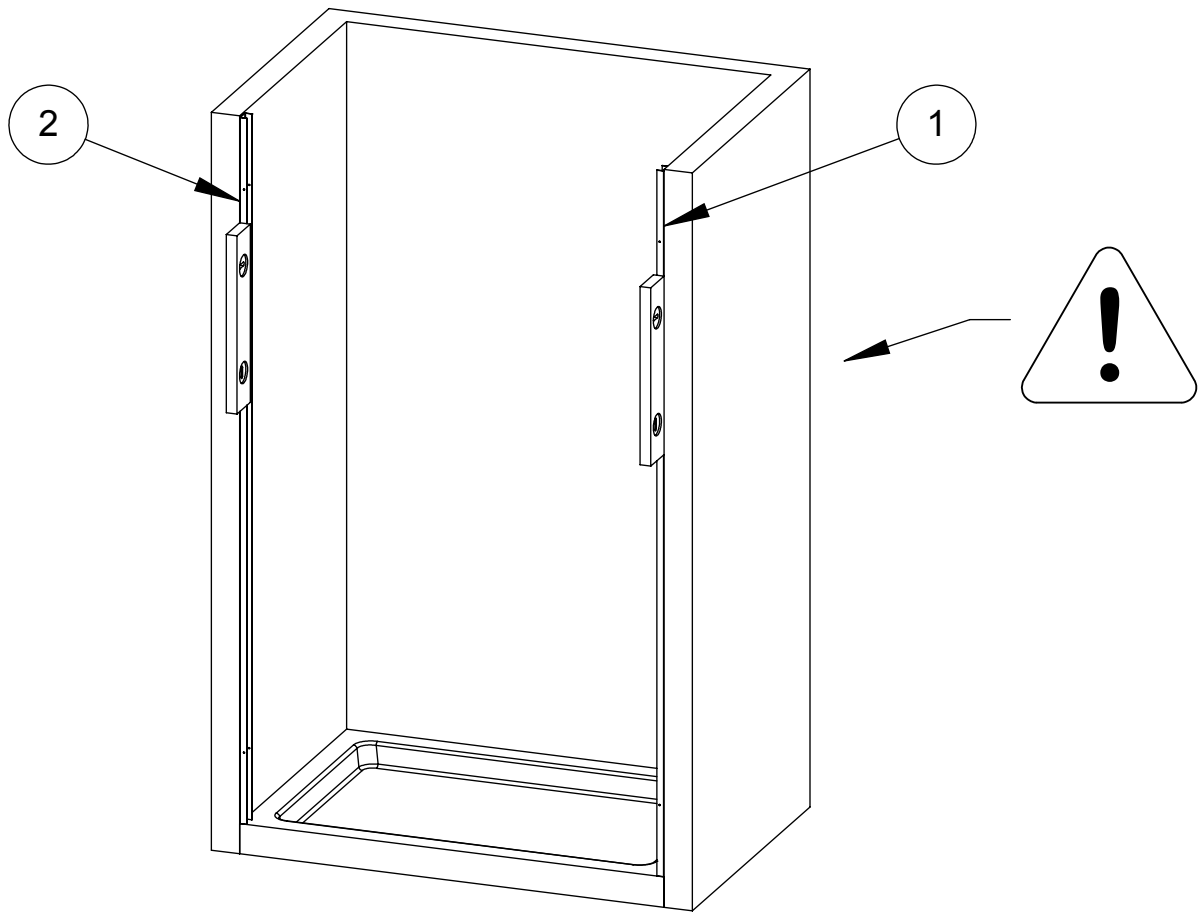

BOLLA

# FASE 10

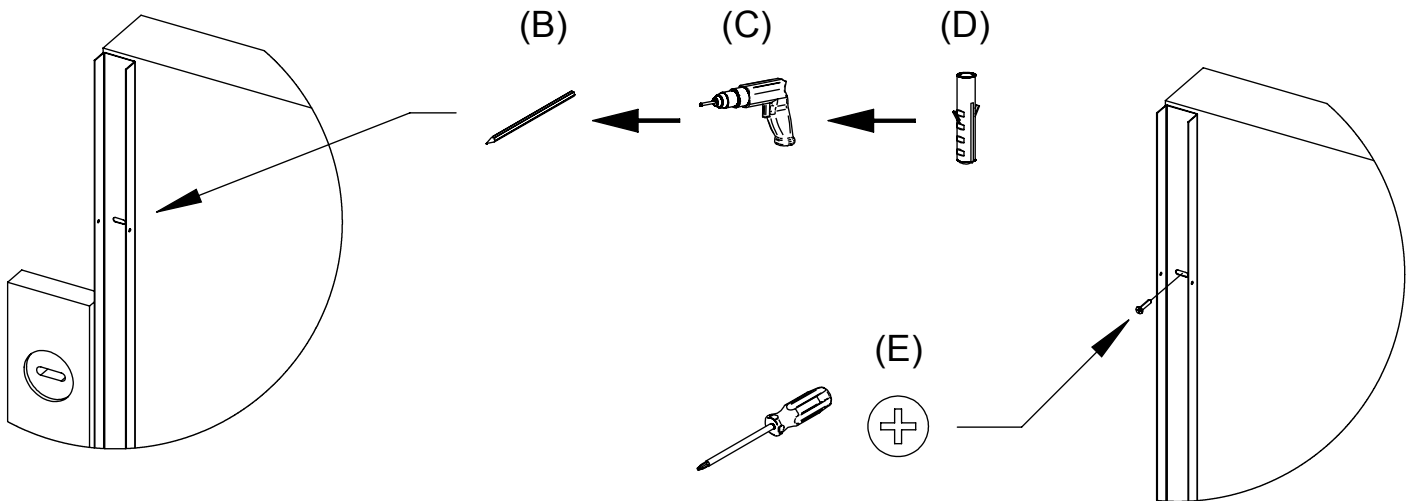

- (A) TOGLIERE LA PELLICOLA PROTETTIVA DAI PROFILI (1) E (2) PRIMA DEL MONTAGGIO
- (B) METTERE A PIOMBO I PROFILI (1) E (2) E UTILIZZARLI PER TRACCIARE LE FORATURE DI FISSAGGIO ALLA PARETE
- (C) ESEGUIRE I FORI PER I TASSELLI
- (D) INSERIRE I TASSELLI
- (E) FISSARE I PROFILI DI COMPENSAZIONE (1) E (2) A MURO TRAMITE LE VITI CON TASSELLI ACCERTANDO CHE I COMPENSATORI SIANO PERFETTAMENTE A PIOMBO



	<b>UTILIZZARE ESCLUSIVAMENTE VITI INOX</b> il non utilizzo di viti inox può trasmettere la presenza di ruggine nella struttura
---	--

## FASE 20

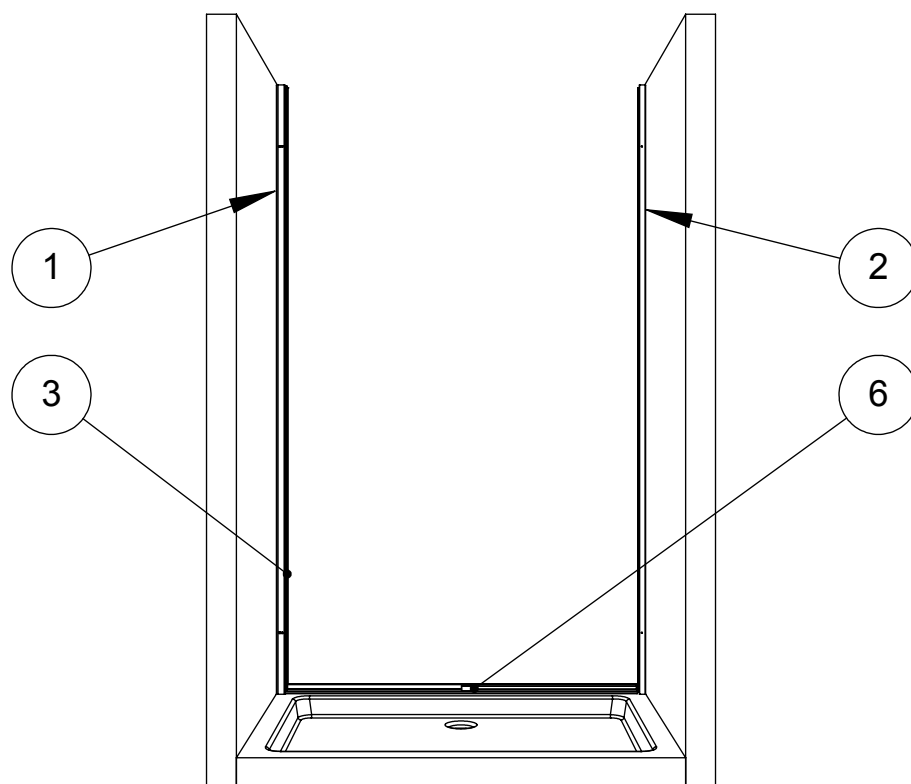

- (A) TOGLIERE LA PELLICOLA PROTETTIVA DAI RIMANENTI PROFILI DEL BOX
- (B) INSERIRE PROFILO (3) NEL PROFILO (1)
- (C) FINSERIRE IL PROFILO A TERRA (6) TRA I DUE COMPENSATORI

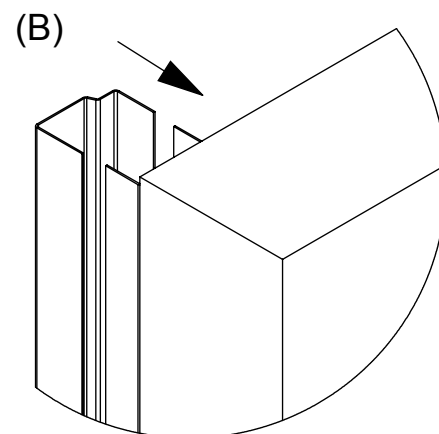
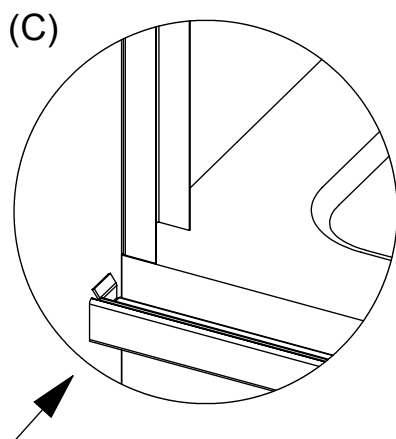

## FASE 30

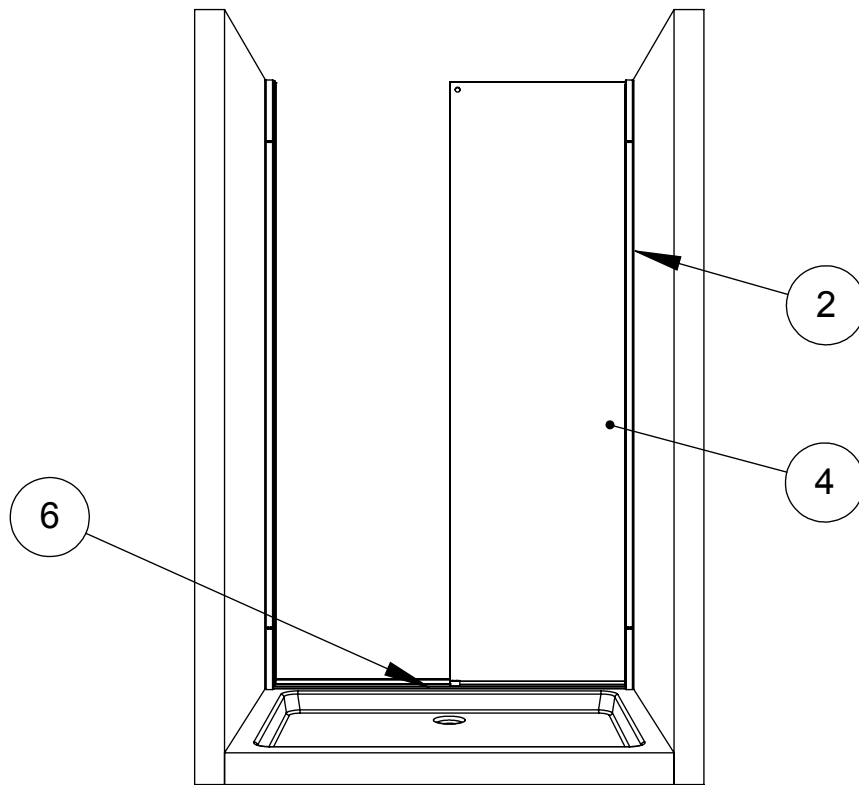

(A) INSERIRE LA PARETE FRONTALE (4) NEL PROFILO DI COMPENSAZIONE (2) E INCASTRARLA CON IL PROFILO A TERRA (6)

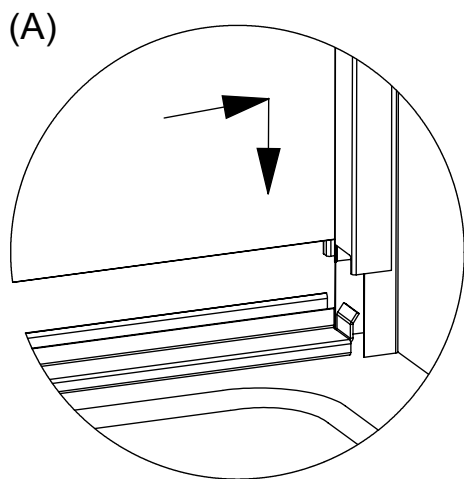

# FASE 40

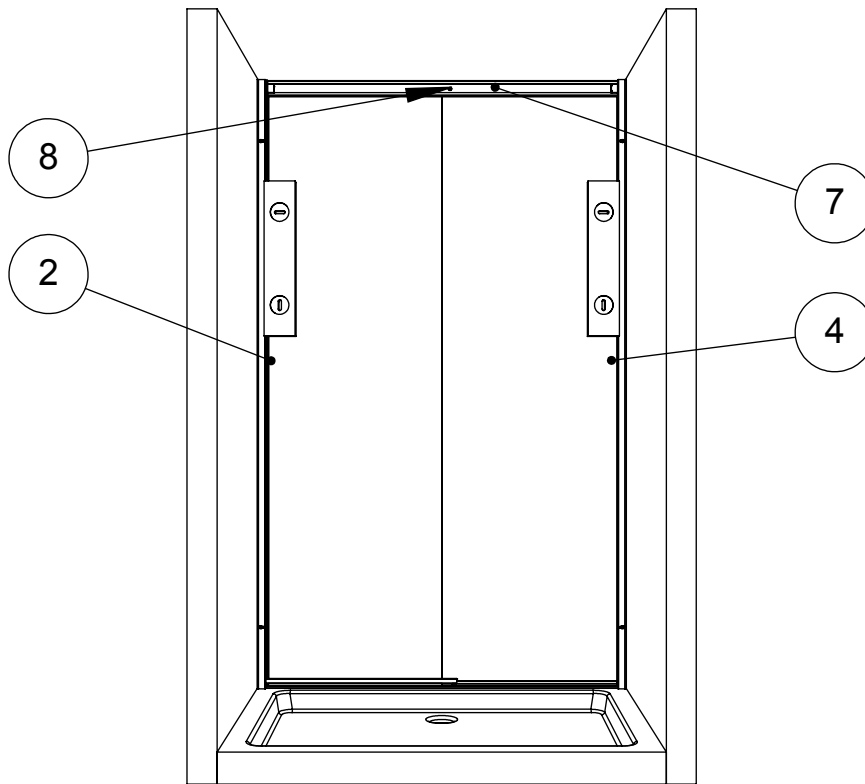

- (A) INSERIRE IL PROFILO DI GUIDA (7) TRA I PROFILI (2 E 4) E FISSARE I TASSELLI MEDIANTE LE VITI (22)
- (B) BLOCCARE LA PARETE FRONTALE MEDIANTE IL TASSELLO (8) E LA VITE (21)
- (C) REGOLARE LA STRUTTURA E BLOCCARE I PROFILI (2) E (4) CON LE VITI (21) IN DOTAZIONE PER OTTENERE LA MESSA IN BOLLA DELLA STRUTTURA

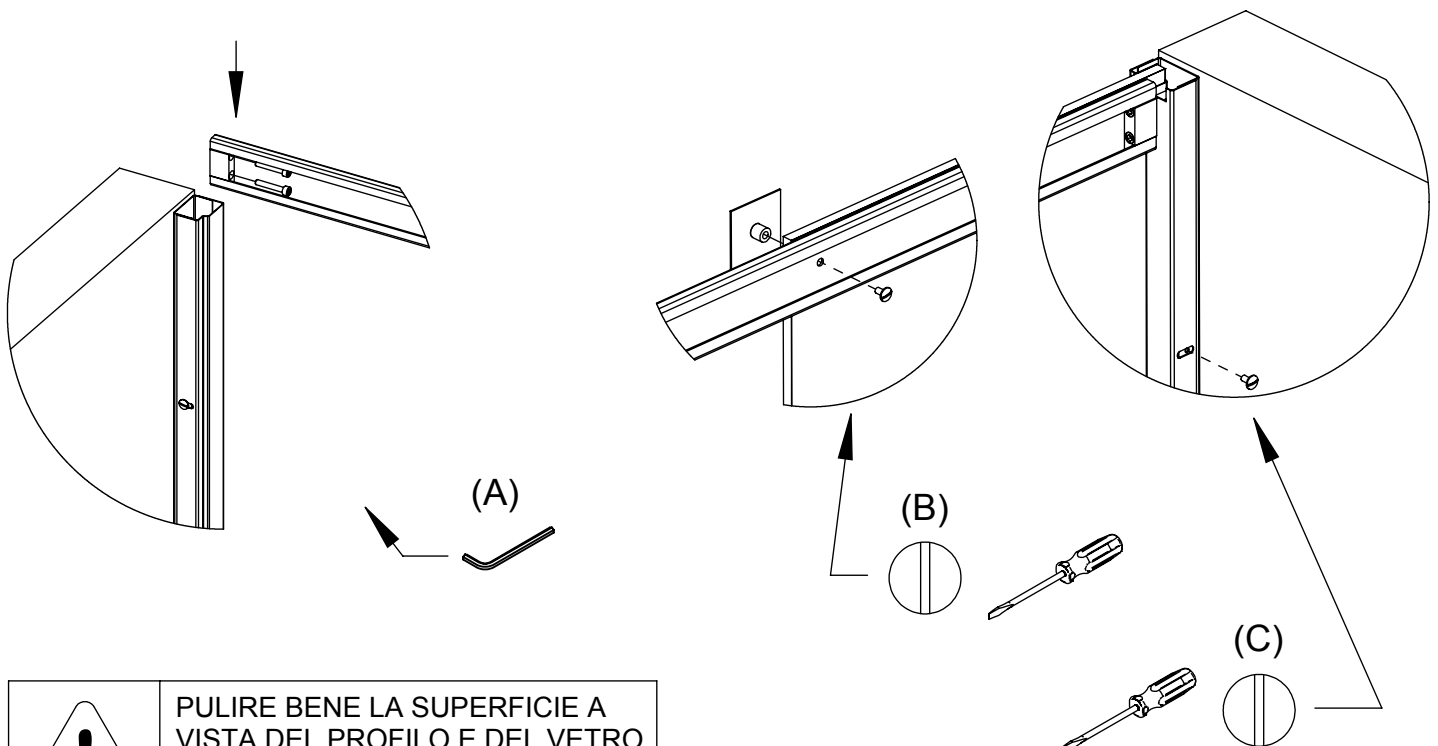

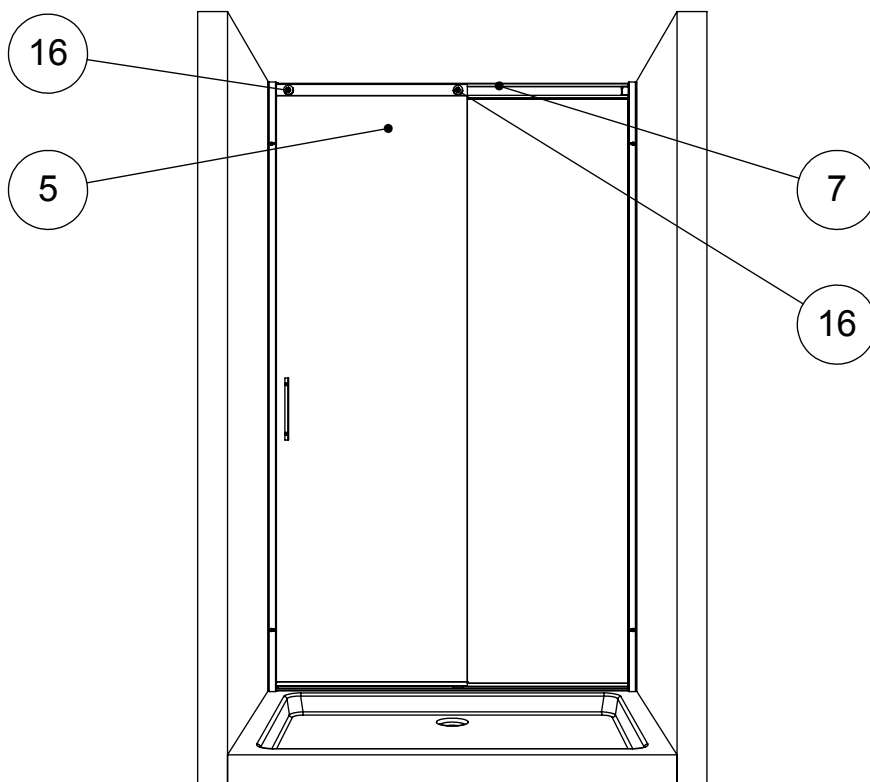

PULIRE BENE LA SUPERFICIE A VISTA DEL PROFILO E DEL VETRO DA SPORCO E IMPRONTE PRIMA DEL FISSAGGIO

# FASE 50

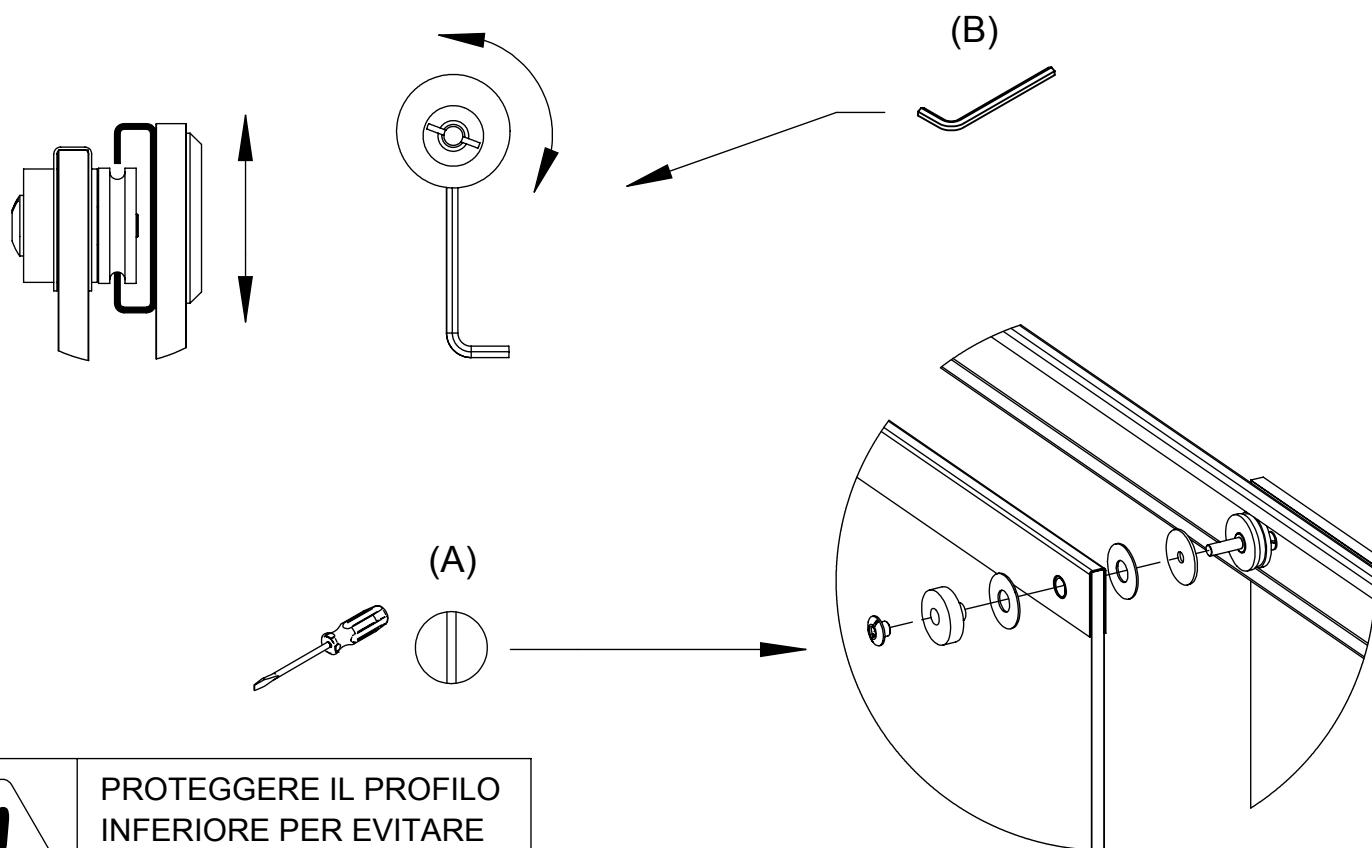

- (A) INSERIRE ANTA (5) CON ASSE RUOTA (16) SU GUIDA (7)
- (B) REGOLARE ANTA IN ALTEZZA TRAMITE CAMMA
- (C) MONTARE MANIGLIA (10)



 **PROTEGGERE IL PROFILO INFERIORE PER EVITARE AMMACCATURE O GRAFFI**



# FASE 60

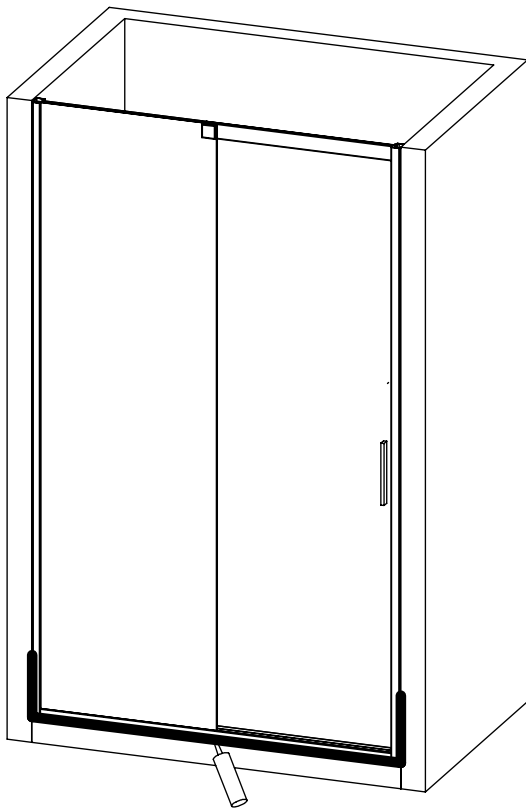

(A) SILICONARE NEL LATO ESTERNO IL  
PROFILO (6)  
SILICONARE NEL LATO ESTERNO I  
PROFILI (1) E (2) DI CIRCA 30 cm

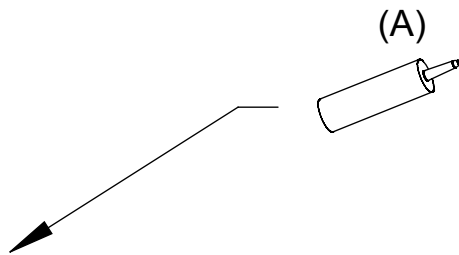

(B) SILICONARE NEL LATO INTERNO I PROFILI (1) E (2)

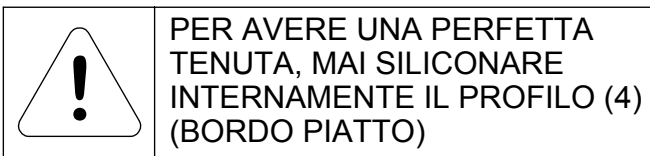

PER AVERE UNA PERFETTA  
TENUTA, MAI SILICONARE  
INTERNAMENTE IL PROFILO (4)  
(BORDO PIATTO)

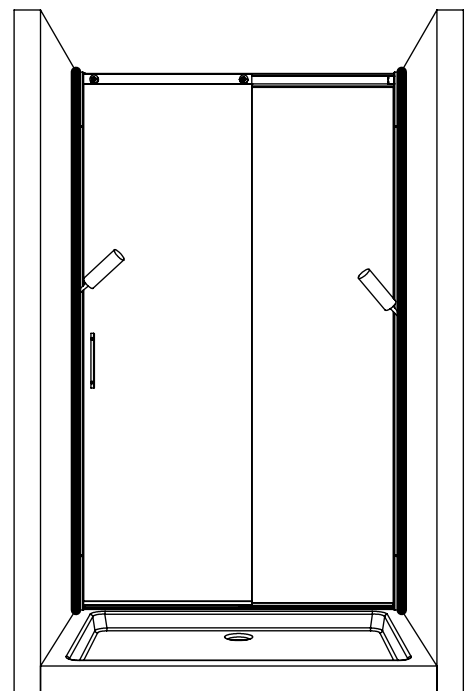
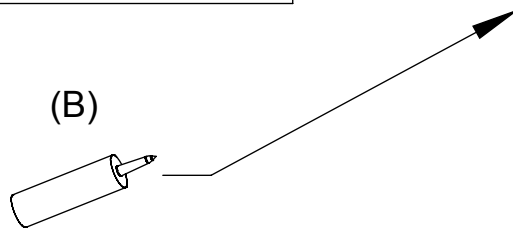

E' consigliabile utilizzare la cabina  
trascorso il periodo di asciugatura  
indicato dal sigillante utilizzato