

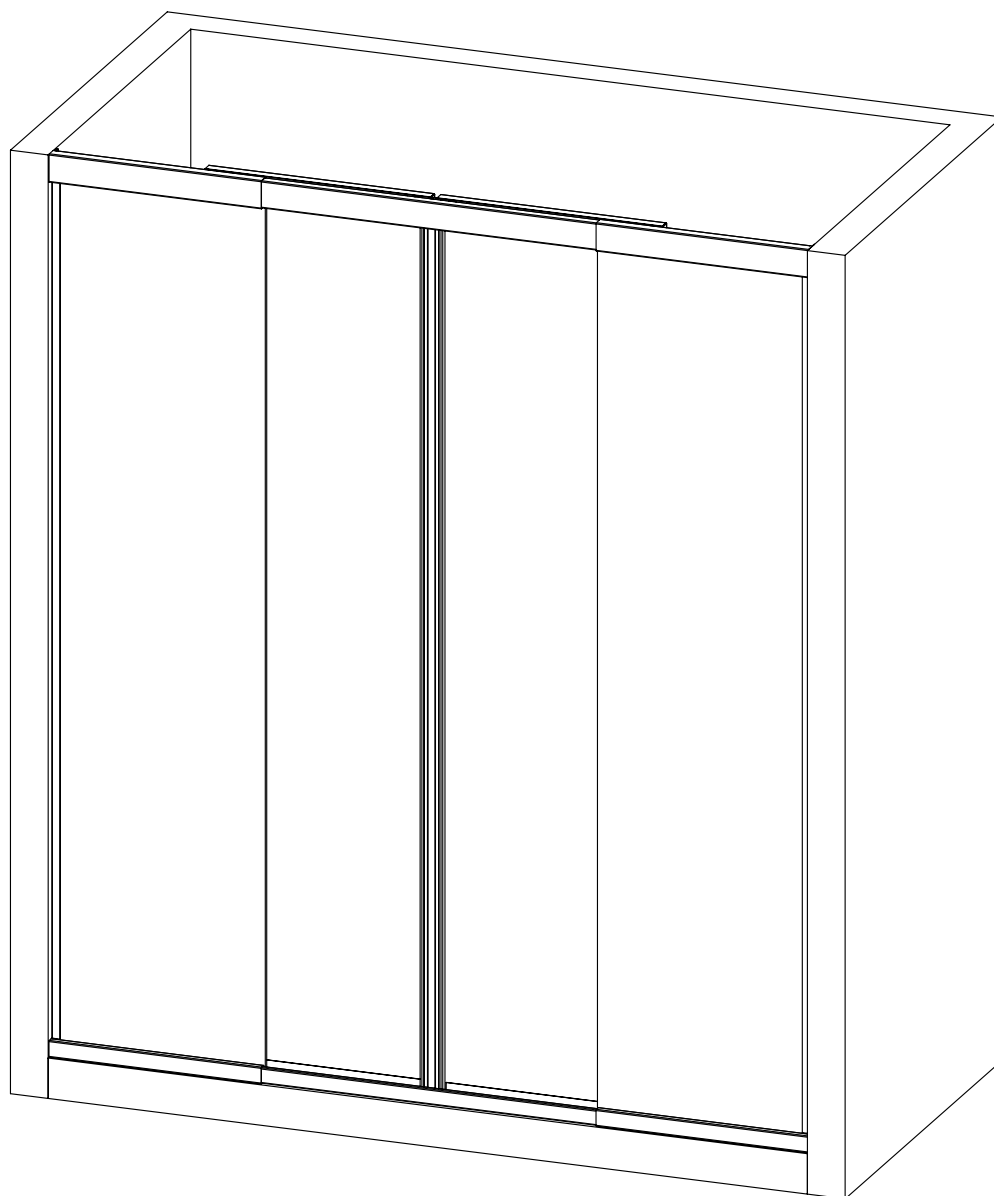

BIANCHI & FONTANA

OASI 101FC



MATERIALE CONTENUTO ALL'INTERNO DELL'IMBALLO COMPOSTO DA 2 SCATOLE:

1. ANTA SCORREVOLE , ANTA FISSA DESTRA E PROFILI TELAIO CON SACCHETTO PER IL FISSAGGIO COMPOSTO DA 4 VITI CON TASSELLI
2. ANTA SCORREVOLE , ANTA FISSA SINISTRA E PROFILI TELAIO CON SACCHETTO PER IL FISSAGGIO COMPOSTO DA 4 VITI CON TASSELLI

CONDIZIONI DI BASE

COMPENSAZIONE STANDARD FINO
ALL'ESTENSIONE MASSIMA DEL BOX

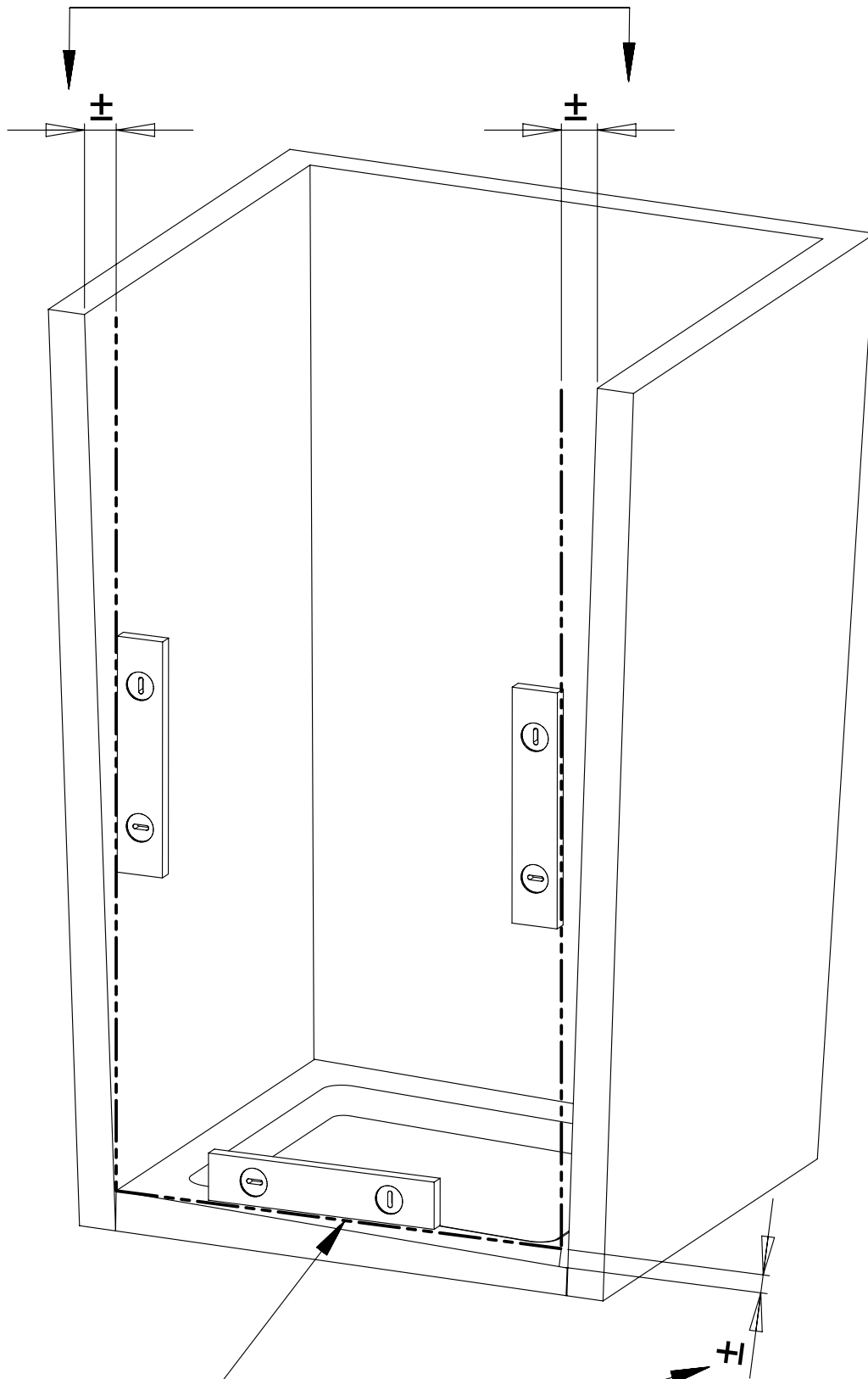

LINEA DI MONTAGGIO

AREA DA SPESSORARE

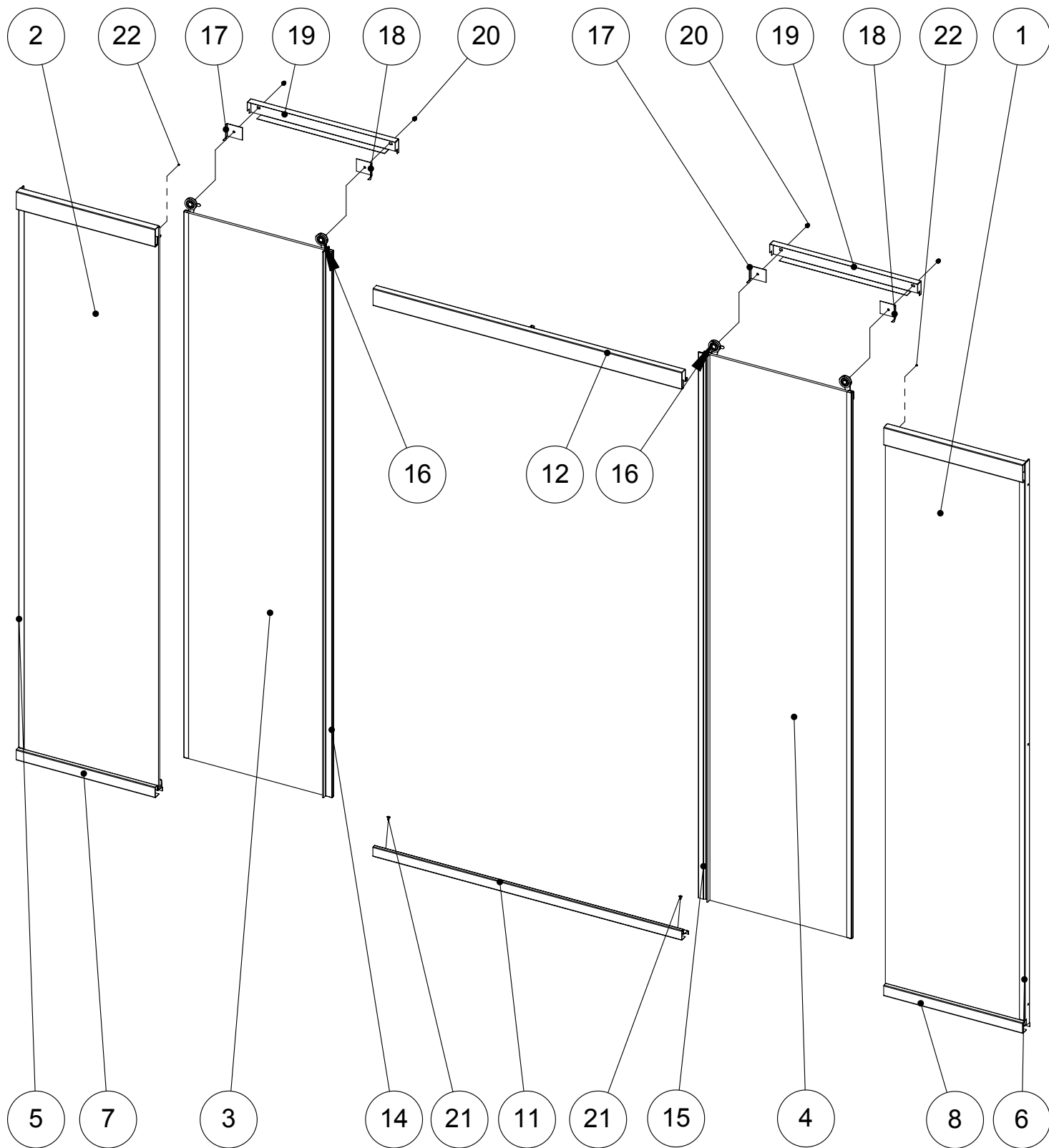

KIT MONTAGGIO DOTAZIONE



8 VITI INOX



8 TASSELLI Ø6

ATTREZZI NECESSARI



CACCIAVITE A CROCE

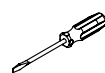

CACCIAVITE A TAGLIO

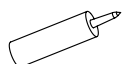

SILICONE

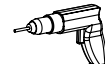

TRAPANO (PUNTA Ø6)



MATITA

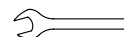

CHIAVE (ch.10)



METRO

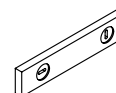

BOLLA

FASE 10

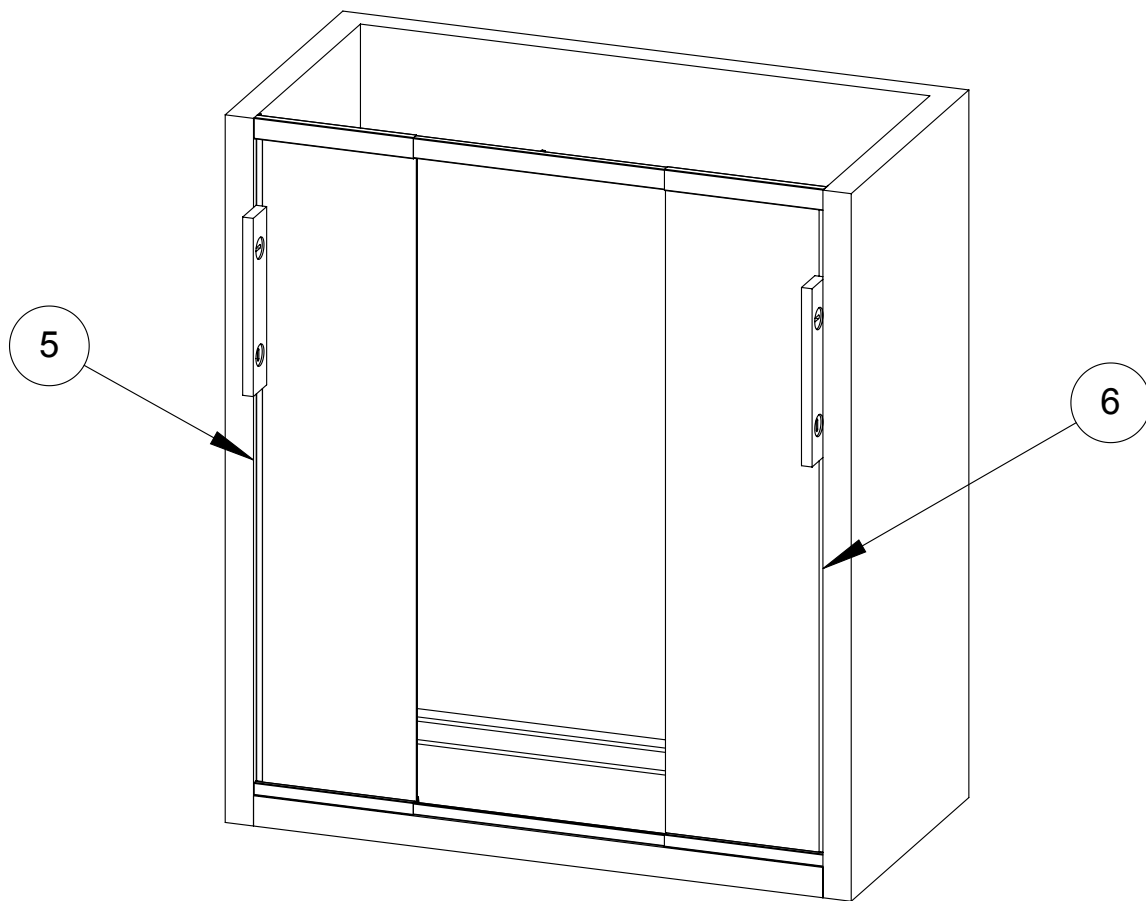

- (A) TOGLIERE LA PELLICOLA PROTETTIVA DAI PROFILI DELLE ANTE FISSE DESTRA E SINISTRA PRIMA DEL MONTAGGIO
- (B) PREASSEMBLARE LA STRUTTURA E INSERIRE IL BOX COMPLETO TRA LE DUE PARETI E IL PIATTO DOCCIA
- (C) POSIZIONARE I PROFILI (5) E (6) E UTILIZZARLI PER TRACCIARE LE FORATURE DI FISSAGGIO ALLA PARETE
- (D) ESEGUIRE I FORI PER I TASSELLI
- (E) INSERIRE I TASSELLI

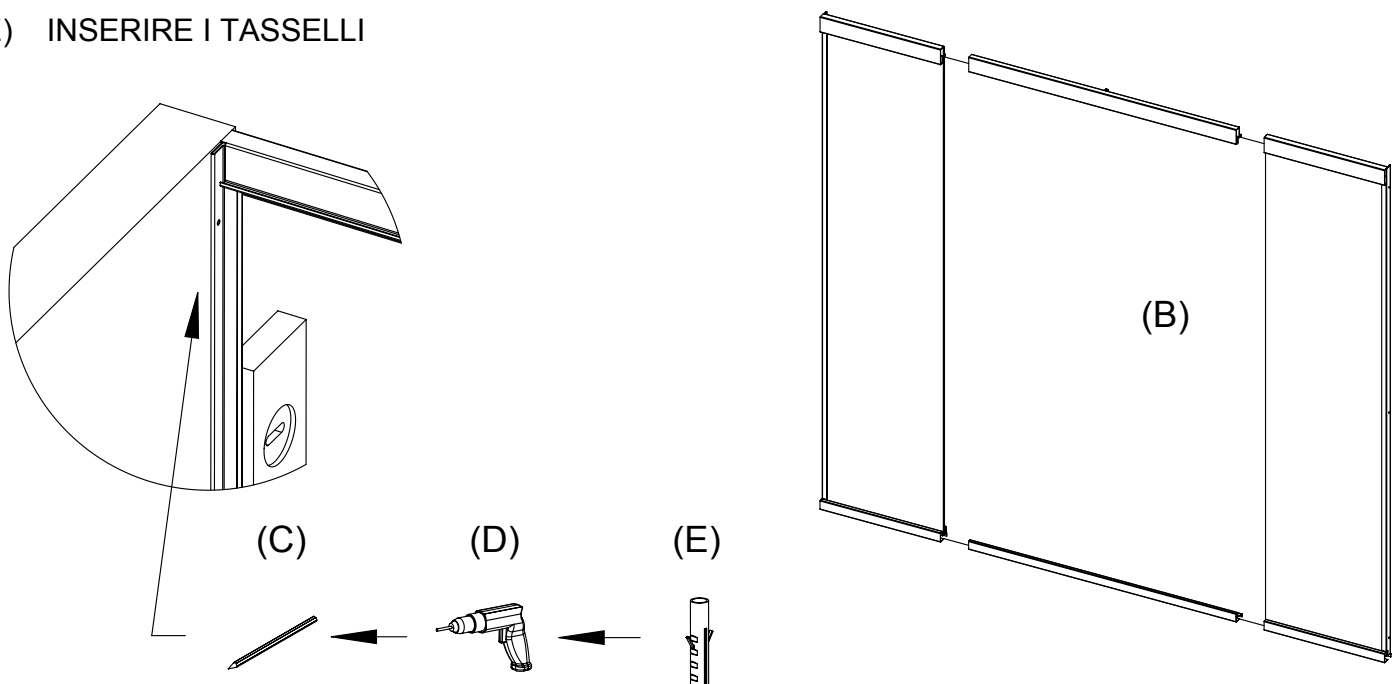

FASE 20

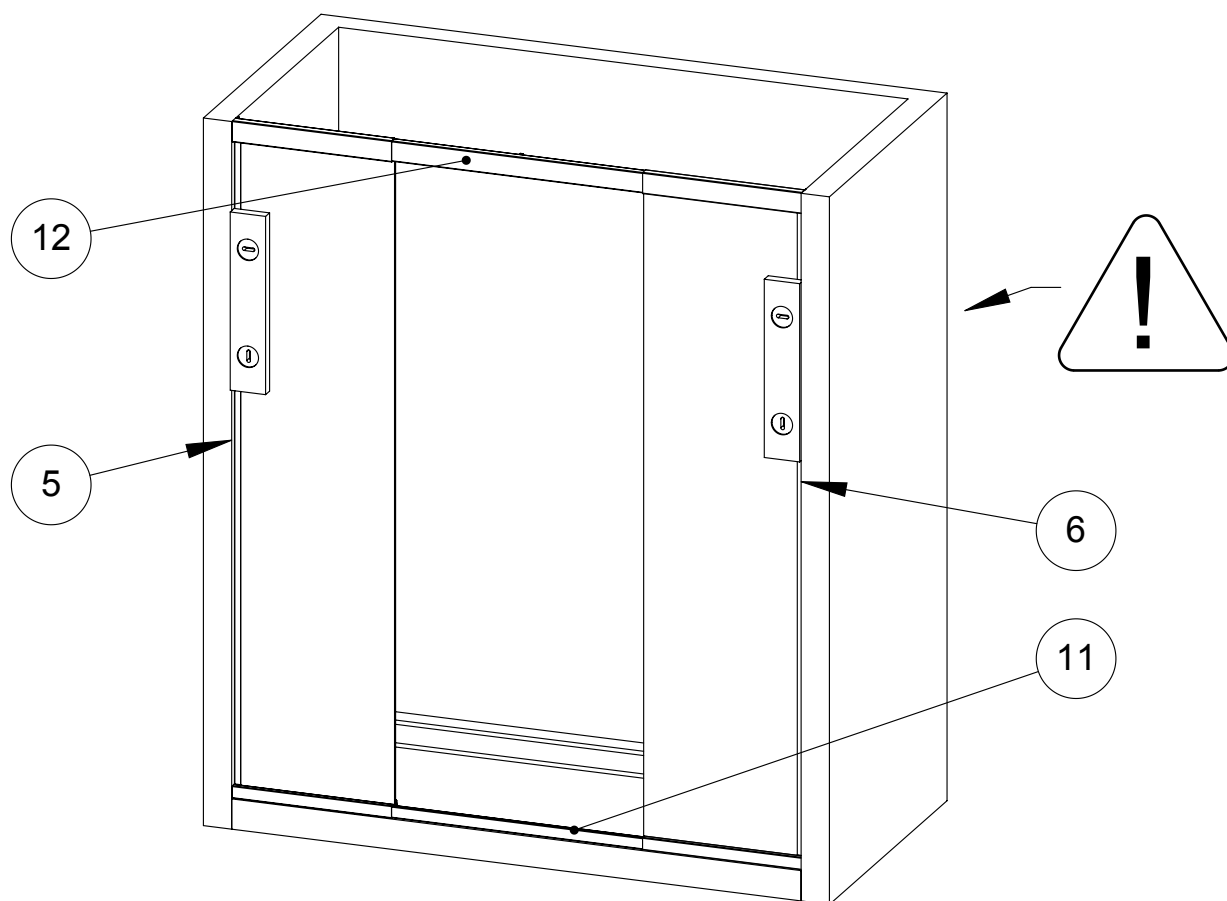

- (A) INSERIRE IL BOX COMPLETO ESCLUSE LE ANTE SCORREVOLI TRA LE DUE PARETI
- (B) REGOLARE L'ESTENSIBILITA' DEL BOX E BLOCCARE I PROFILI ESTENSIBILI INFERIORI CON LE VITI (21) E I PROFILI SUPERIORI CON LE VITI (22)
- (C) REGOLARE LA STRUTTURA E FISSARE I PROFILI (5) E (6) A MURO TRAMITE LE VITI CON TASSELLI

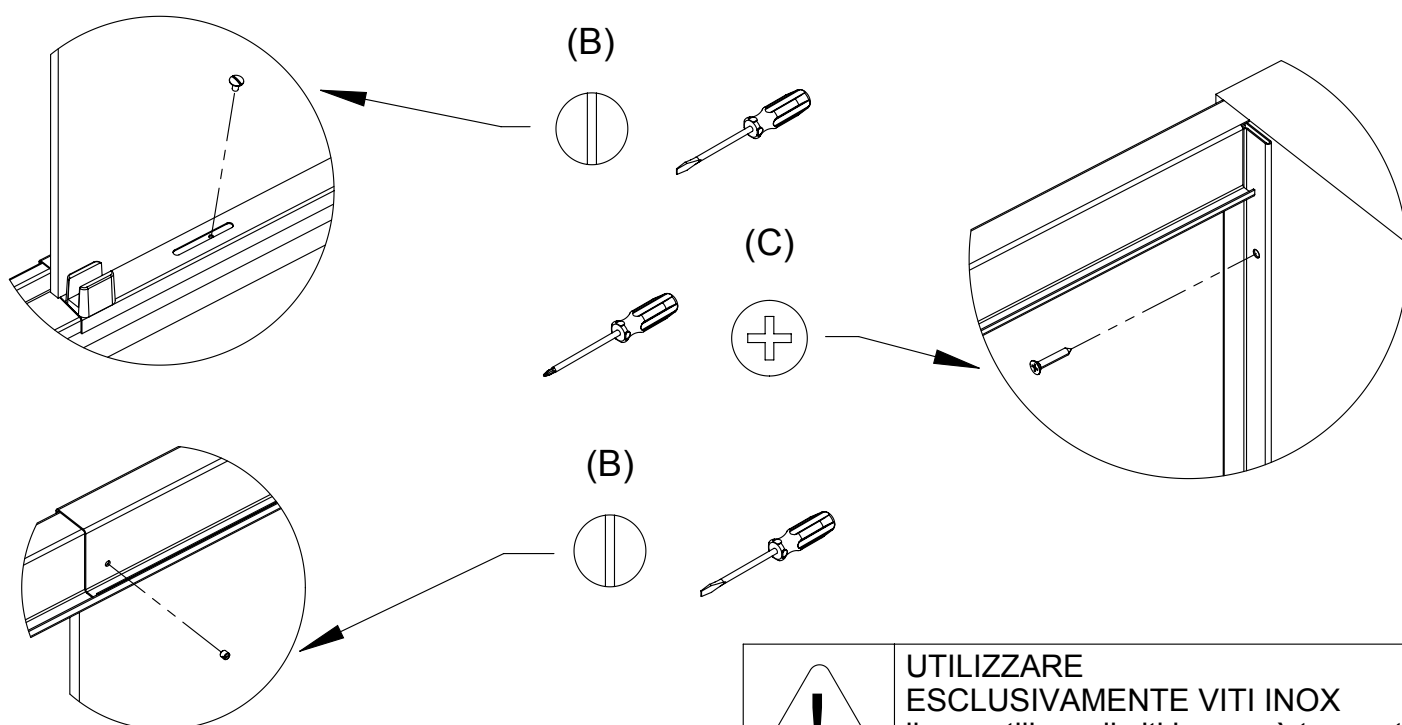

 **UTILIZZARE ESCLUSIVAMENTE VITI INOX**
il non utilizzo di viti inox può trasmettere la presenza di ruggine nella struttura

FASE 30

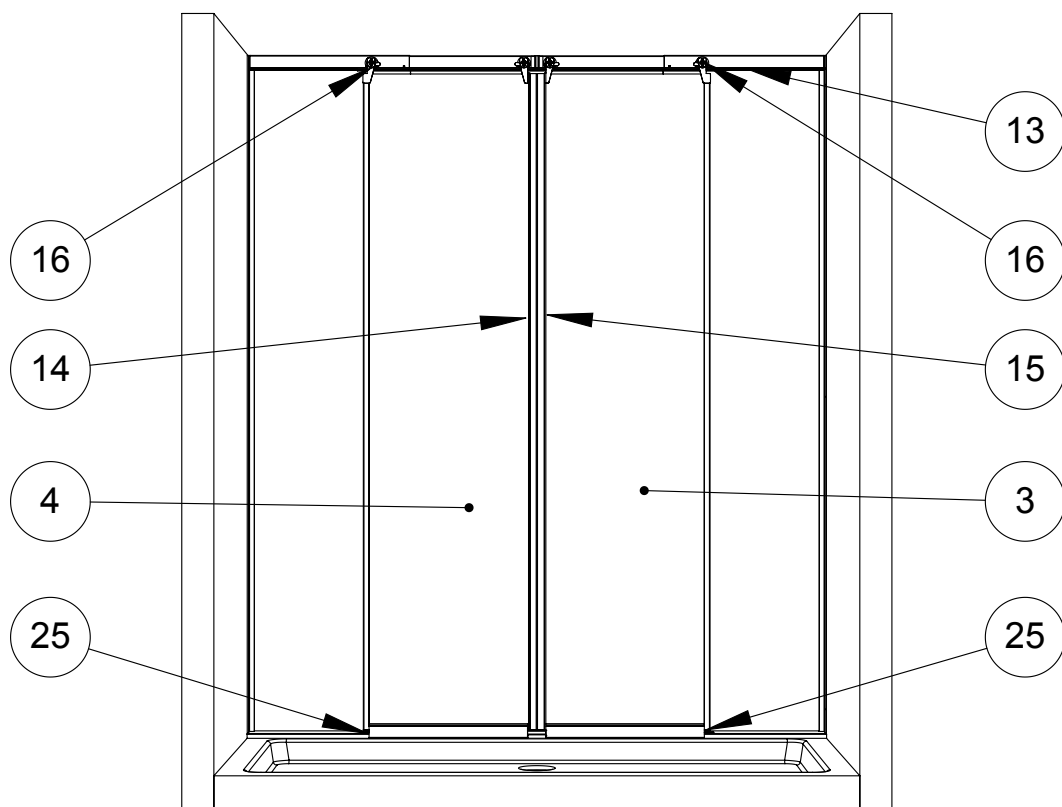

- (A) TOGLIERE LA PELLICOLA PROTETTIVA DAI PROFILI DELLE ANTE SCORREVOLI
- (B) MONTARE LE ANTE SCORREVOLI (3) E (4) INSERENDOLE NEI TASSELLI (25) POSTI SUI PROFILI TELESCOPICI INFERIORI
- (C) POSIZIONARE LE RUOTE (16) NELL'APPOSITA GUIDA SUL PROFILO DI SCORRIMENTO (13)
- (D) ACCOSTARE I PROFILI (14) E (15) DELLE ANTE SCORREVOLI E REGOLARE GLI ECCENTRICI DELLE RUOTE AL FINE DI OTTENERE UNA CHIUSURA PERFETTA

(B)

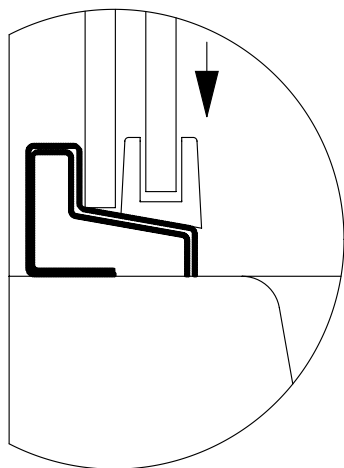

(C)

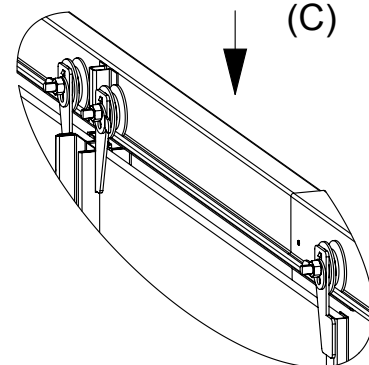

(D)

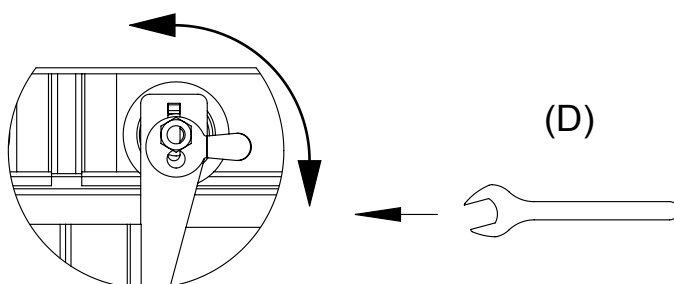

FASE 40

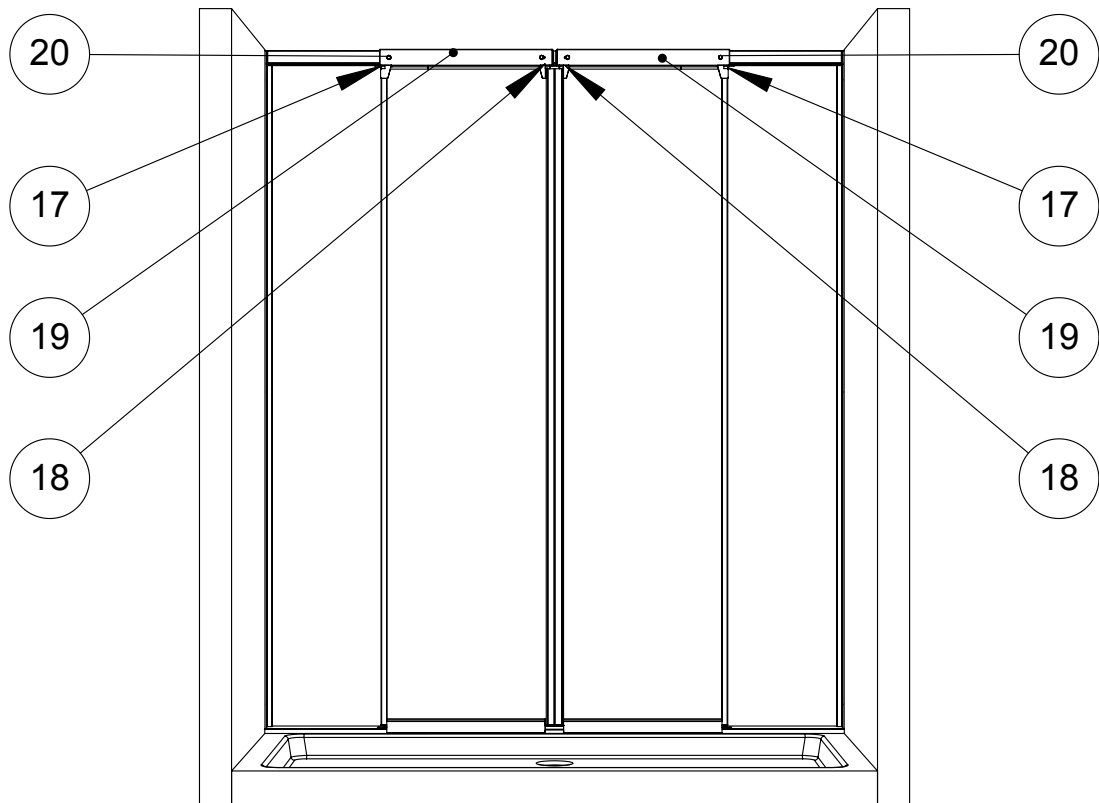

- (A) MONTARE I GANCI ANTI-SCARRUCOLAMENTO (17) E (18) SULLE RUOTE E CHIUDERE CON I PROFILI DI COPERTURA (19) FISSANDOLI ALLE RUOTE CON I DADI ESAGONALI CHIUSI (20)

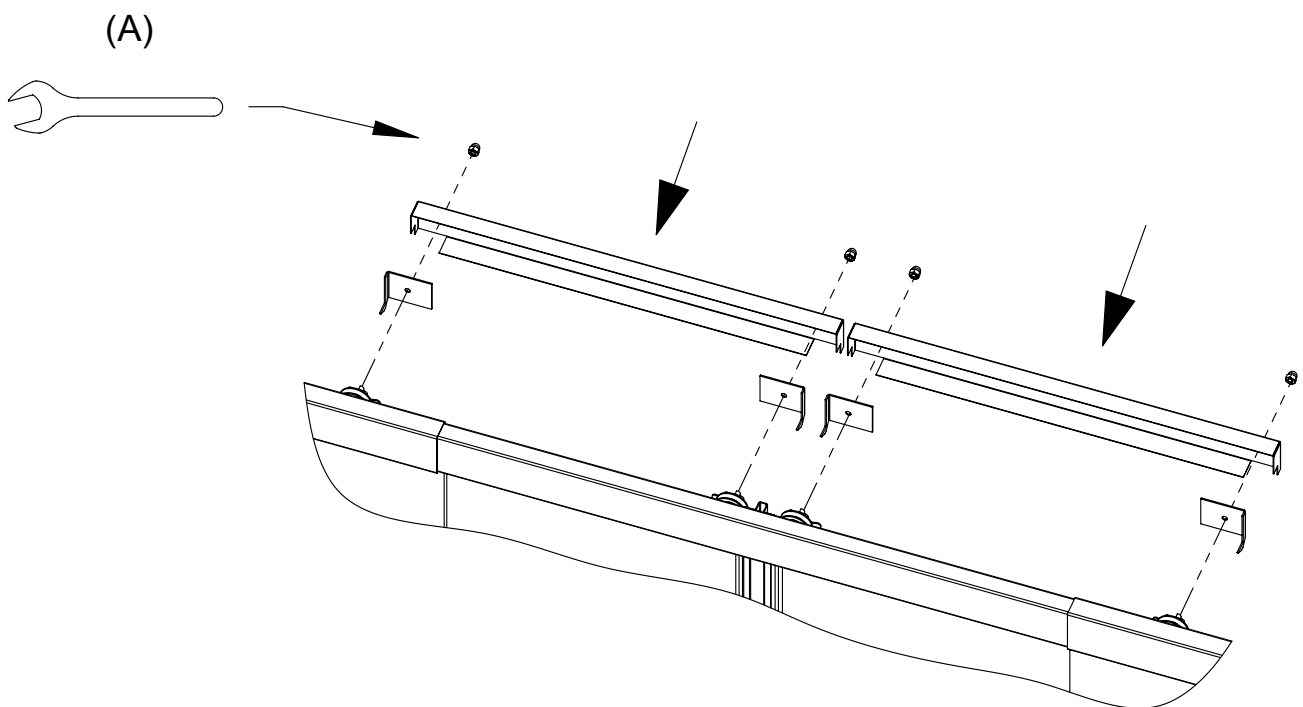

FASE 50

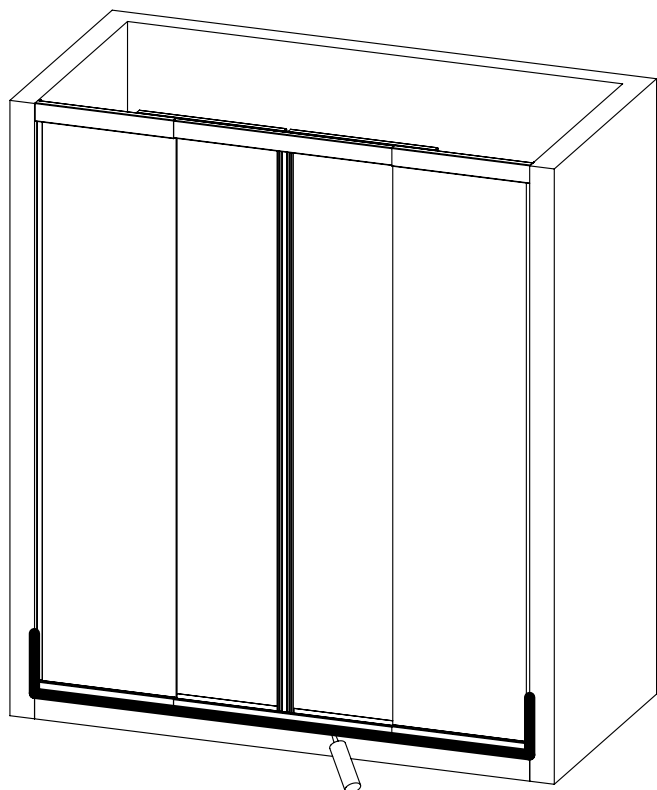

(A) SILICONARE NEL LATO ESTERNO
I PROFILI (7) , (8) E (11)

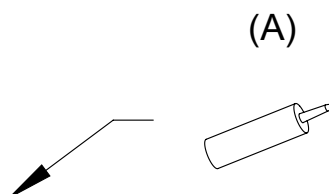

(B) SILICONARE NEL LATO INTERNO
I PROFILI (5) E (6)

