

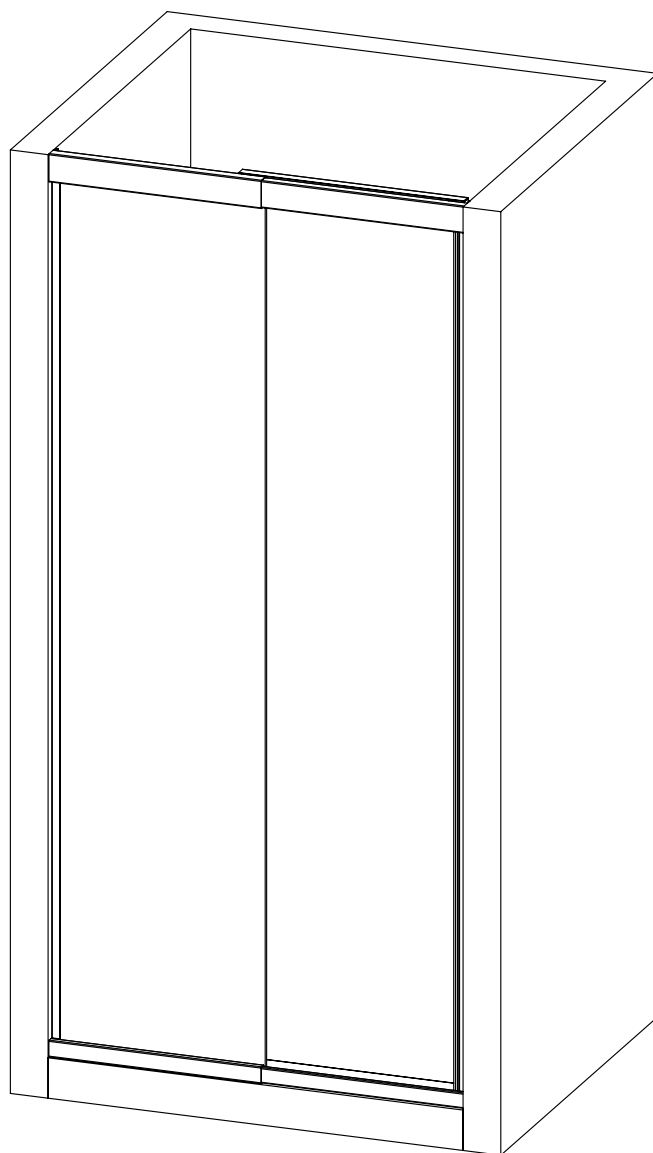

BIANCHI & FONTANA

OASI 101P



MATERIALE CONTENUTO ALL'INTERNO DELL'IMBALLO COMPOSTO DA 2 SCATOLE:

1. ANTA SCORREVOLE
2. ANTA FISSA E PROFILI TELAIO CON SACCHETTO PER IL FISSAGGIO COMPOSTO DA 8 VITI CON TASSELLI

CONDIZIONI DI BASE

COMPENSAZIONE STANDARD FINO
ALL'ESTENSIONE MASSIMA DEL BOX

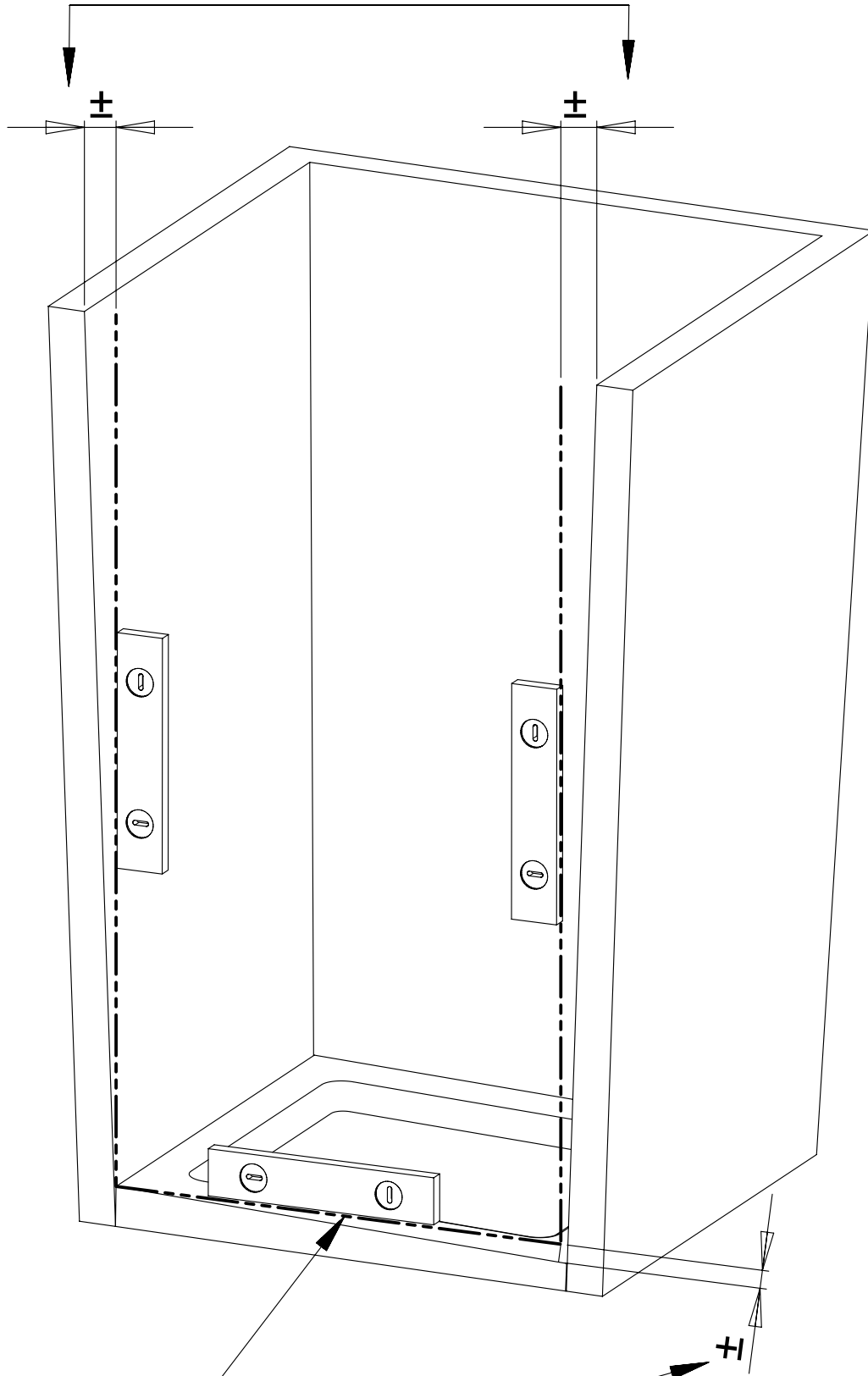

LINEA DI MONTAGGIO

AREA DA SPESSORARE

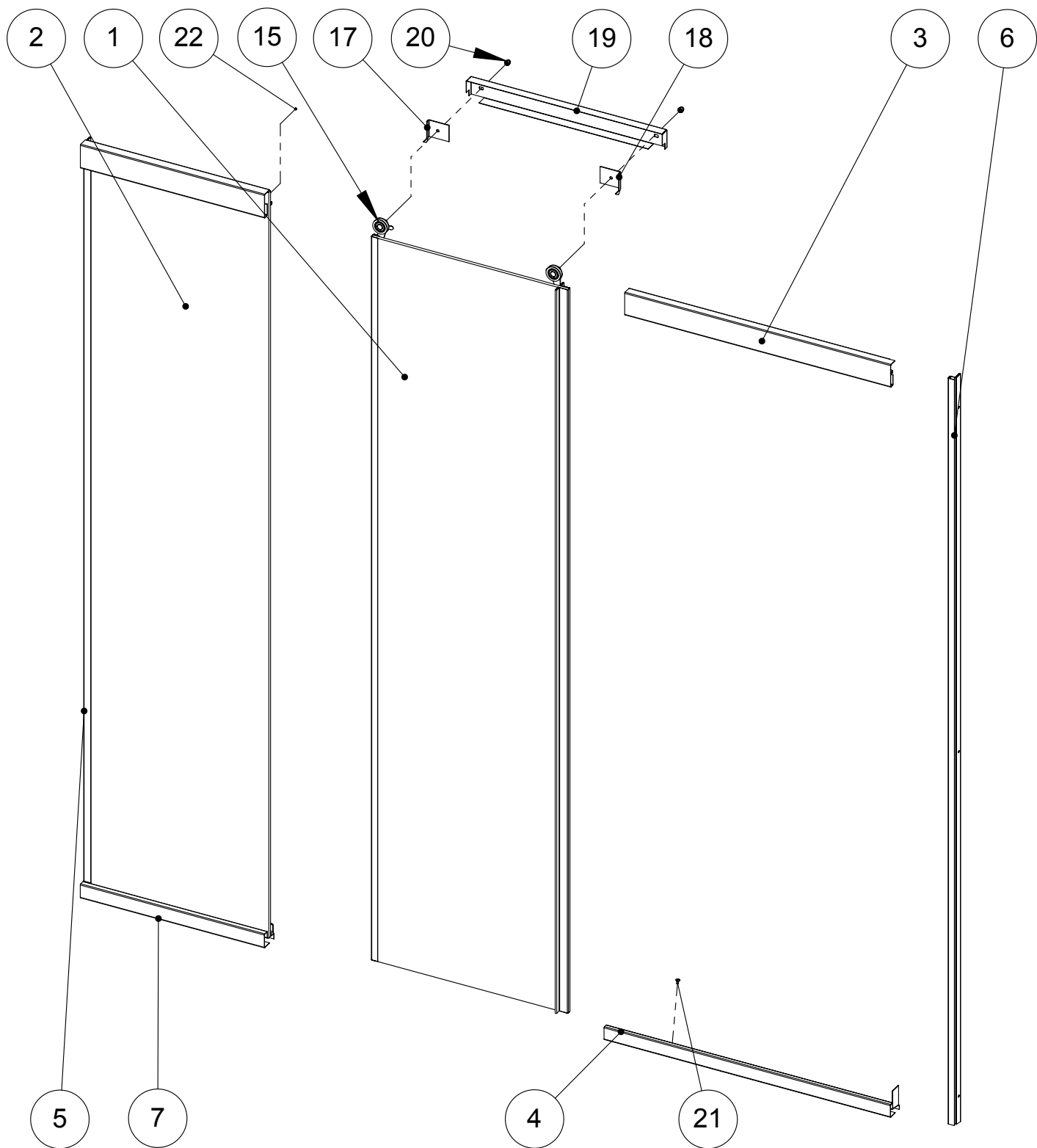

KIT MONTAGGIO DOTAZIONE



8 VITI INOX



8 TASSELLI Ø6

ATTREZZI NECESSARI

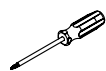

CACCIAVITE A CROCE

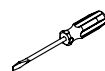

CACCIAVITE A TAGLIO

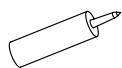

SILICONE



TRAPANO (PUNTA Ø6)



MATITA



CHIAVE (ch.10)



METRO

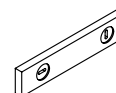

BOLLA

FASE 10

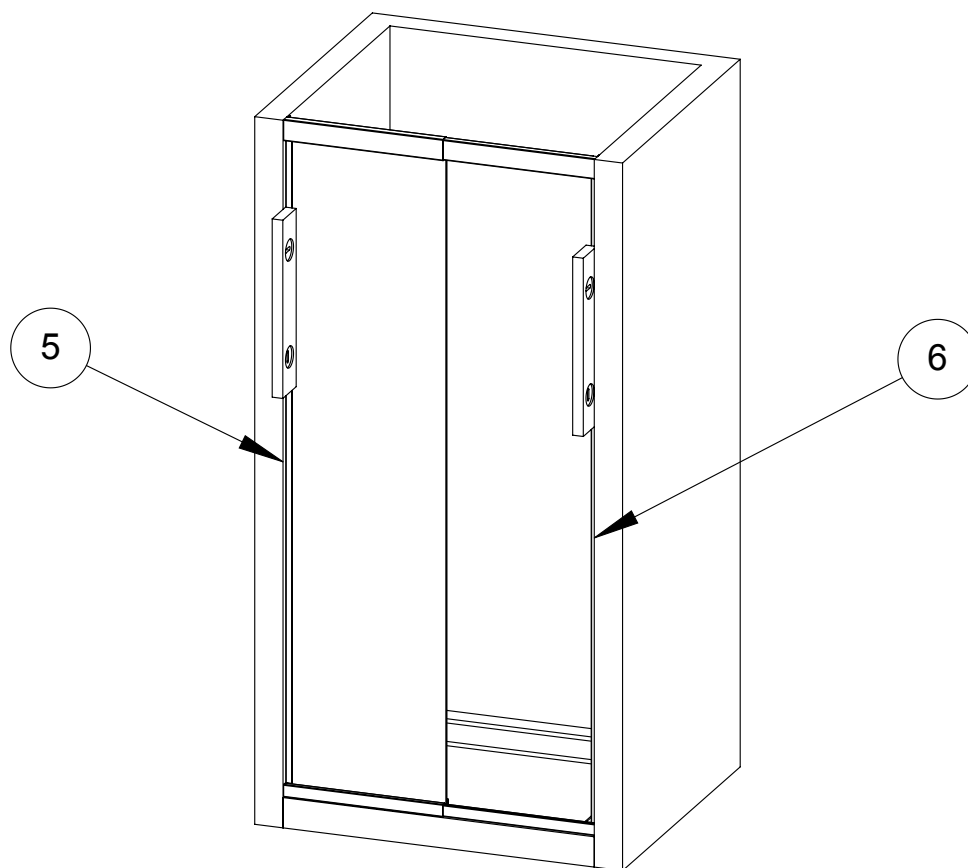

- (A) TOGLIERE LA PELLICOLA PROTETTIVA DAI PROFILI DELL'ANTA FISSA PRIMA DEL MONTAGGIO
- (B) PREASSEMBLARE LA STRUTTURA E INSERIRE IL BOX COMPLETO TRA LE DUE PARETI E IL PIATTO DOCCIA
- (C) POSIZIONARE I PROFILI (5) E (6) E UTILIZZARLI PER TRACCIARE LE FORATURE DI FISSAGGIO ALLA PARETE
- (D) ESEGUIRE I FORI PER I TASSELLI
- (E) INSERIRE I TASSELLI

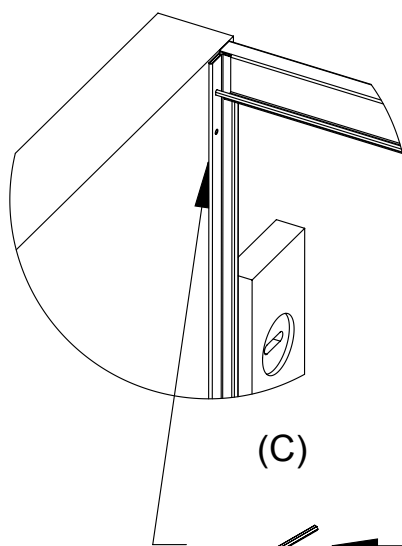

(C)

(D)

(E)

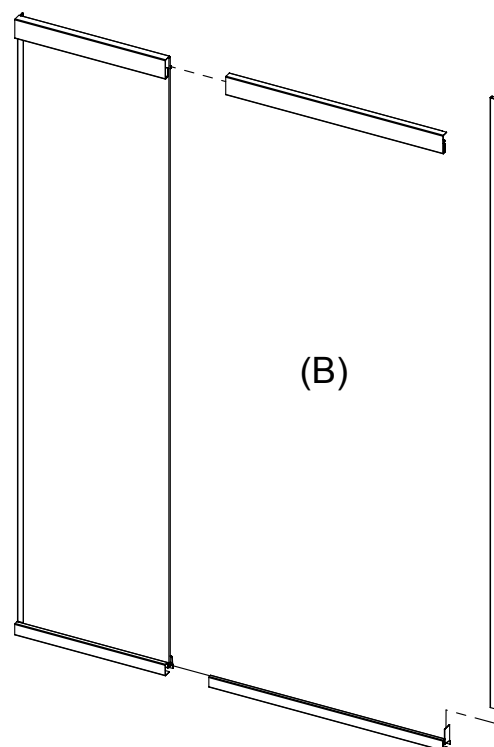
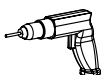

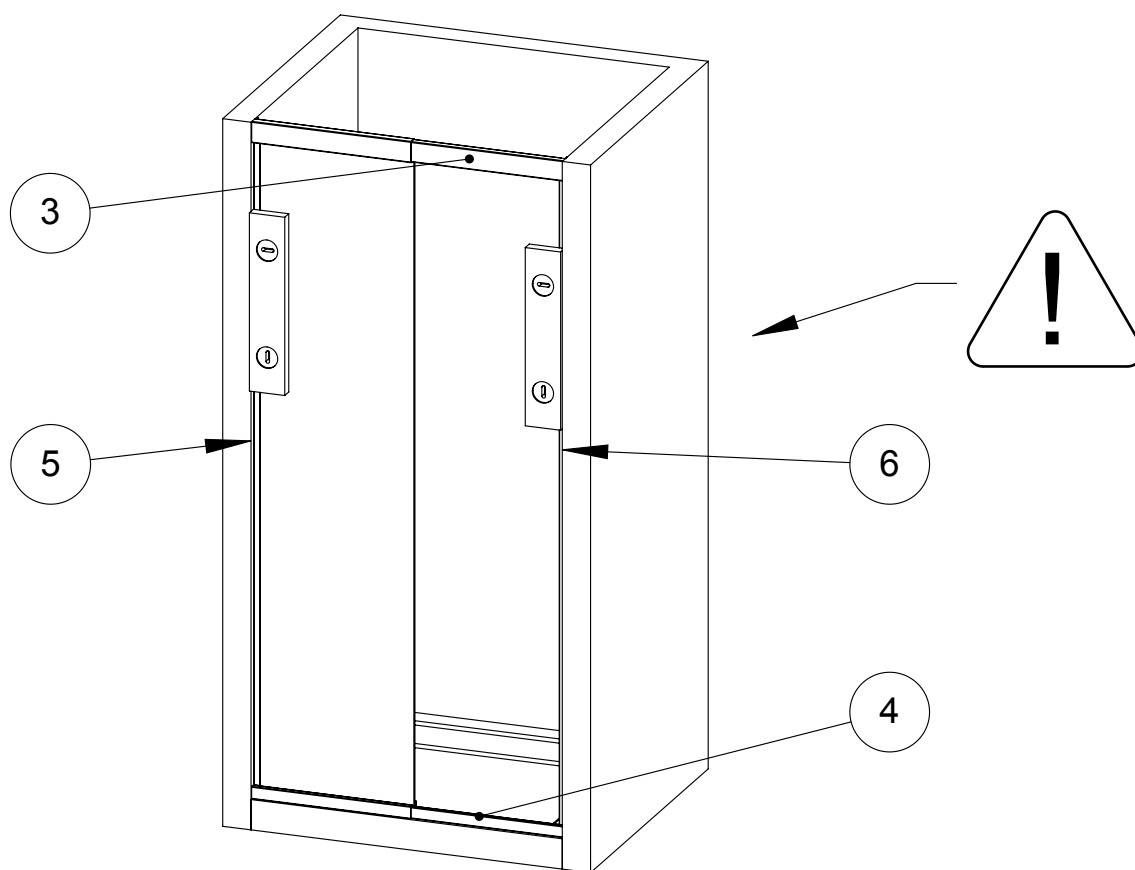

(B)

FASE 20

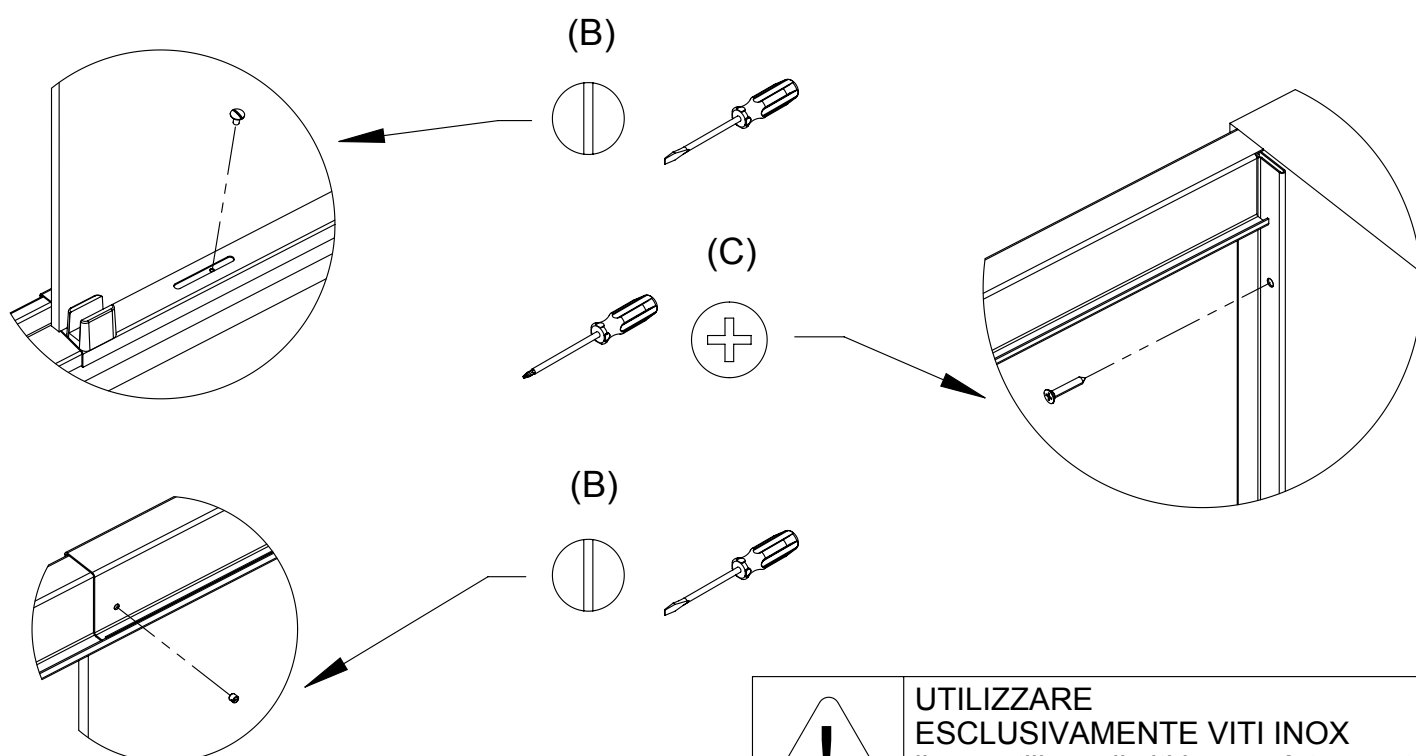

- (A) INSERIRE IL BOX COMPLETO ESCLUSA L'ANTA SCORREVOLE TRA LE DUE PARETI
- (B) REGOLARE L'ESTENSIBILITA' DEL BOX E BLOCCARE I PROFILI ESTENSIBILI INFERIORI CON LA VITE (21) E I PROFILI SUPERIORI CON LA VITE (22)
- (C) REGOLARE LA STRUTTURA E FISSARE I PROFILI (5) E (6) A MURO TRAMITE LE VITI CON TASSELLI



 **UTILIZZARE ESCLUSIVAMENTE VITI INOX**
il non utilizzo di viti inox può trasmettere la presenza di ruggine nella struttura

FASE 30

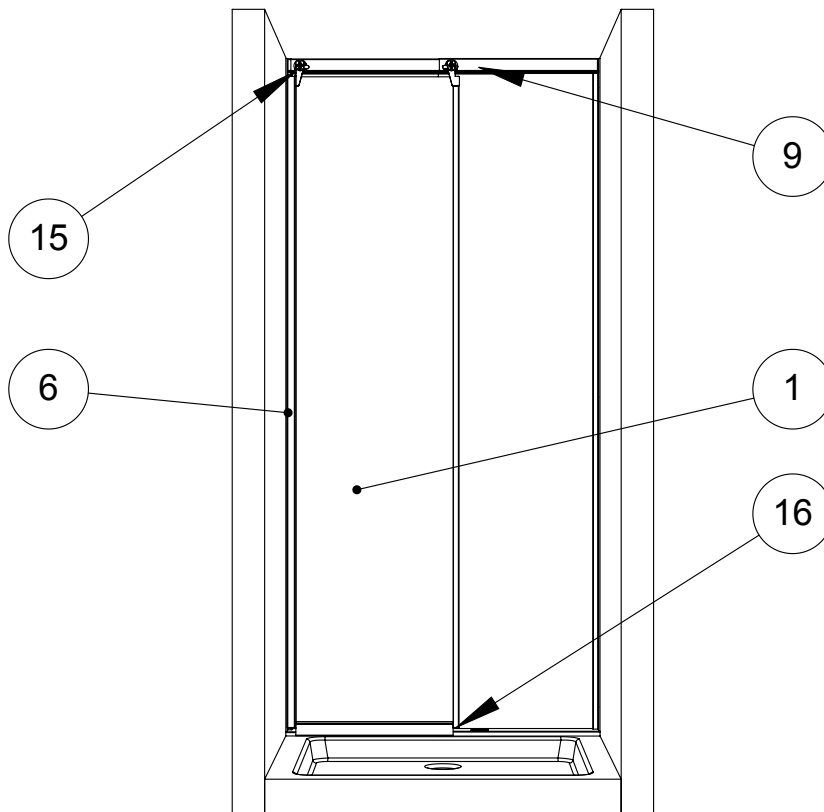

- (A) TOGLIERE LA PELLICOLA PROTETTIVA DAI PROFILI DELL'ANTA SCORREVOLE
- (B) MONTARE L'ANTA SCORREVOLE (1) INSERENDOLA NEL TASSELLO (16) POSTO SUL PROFILO TELESCOPICO INFERIORE
- (C) POSIZIONARE LE RUOTE (15) NELL'APPOSITA GUIDA SUL PROFILO DI SCORRIMENTO (9)
- (D) ACCOSTARE L'ANTA SCORREVOLE AL PROFILO (6) E REGOLARE GLI ECCENTRICI DELLE RUOTE AL FINE DI OTTENERE UNA CHIUSURA PERFETTA

(B)

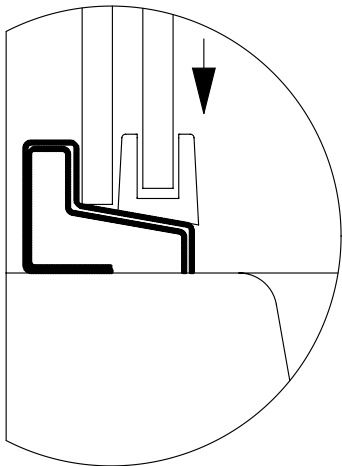

(C)

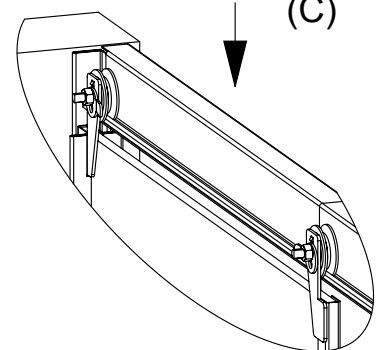

(D)

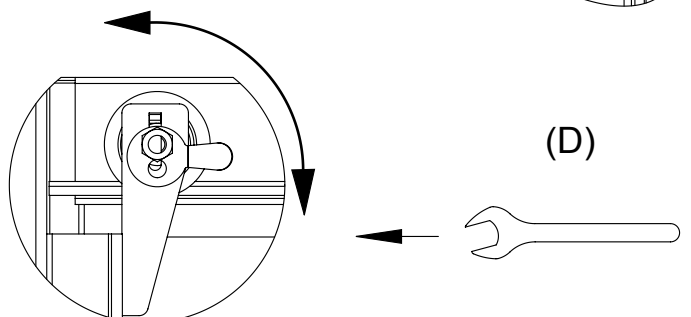

FASE 40

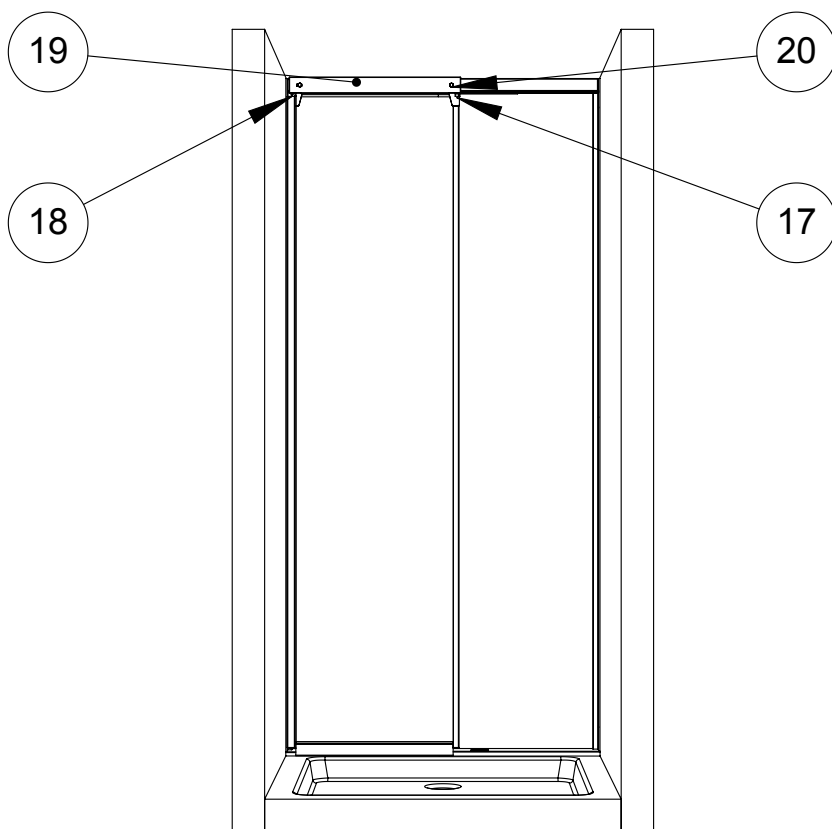

- (A) MONTARE I GANCI ANTI-SCARRUCOLAMENTO (17) E (18) SULLE RUOTE E CHIUDERE CON IL PROFILO DI COPERTURA (19) FISSANDOLO ALLE RUOTE CON I DADI ESAGONALI CHIUSI (20)

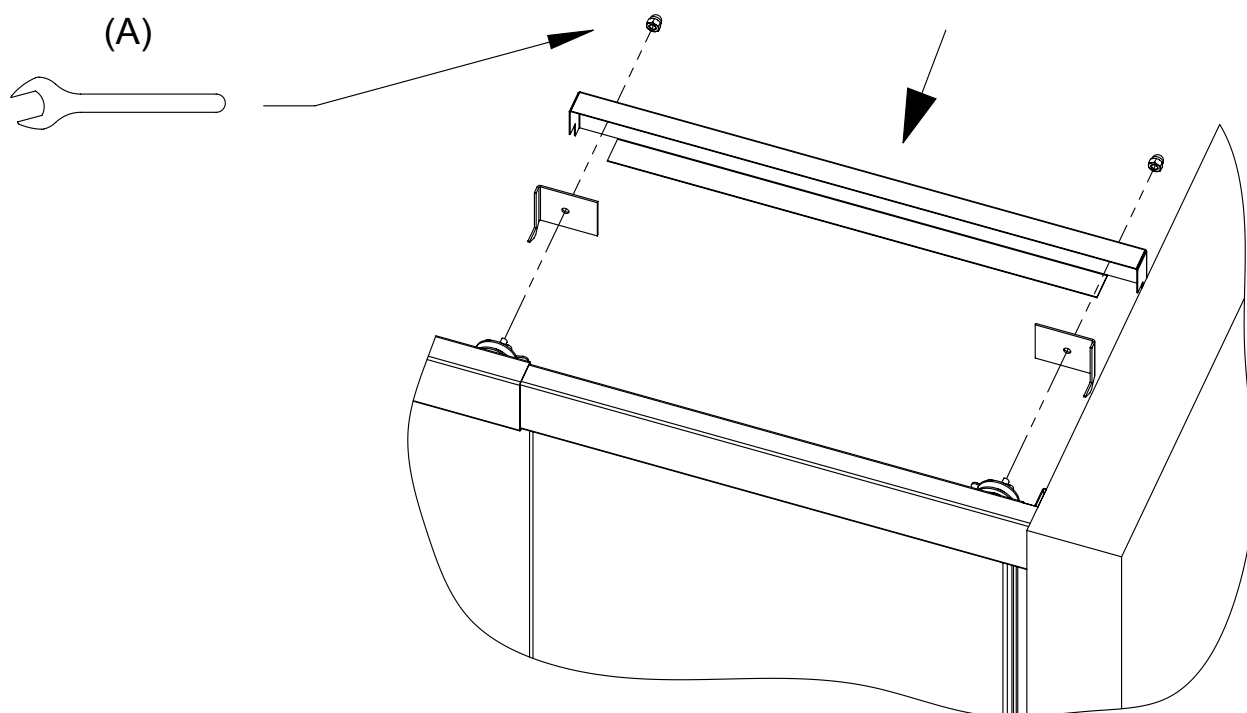

FASE 50

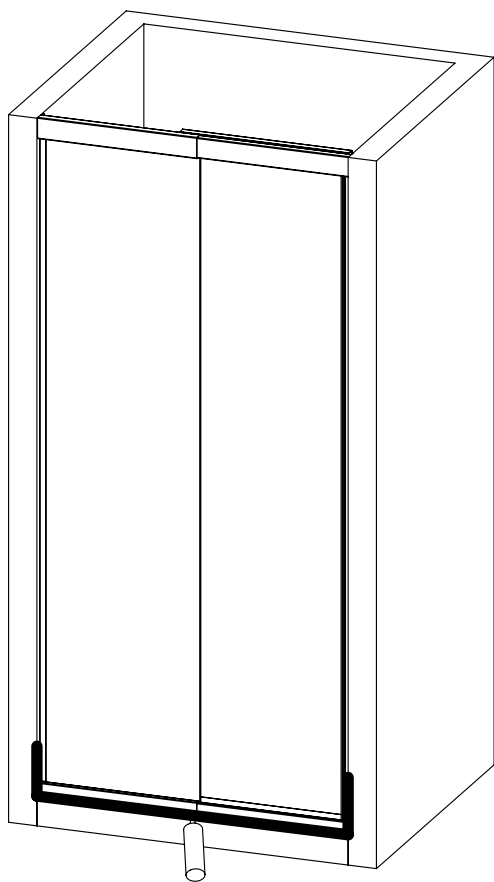

(A) SILICONARE NEL LATO ESTERNO
I PROFILI (4) E (7)

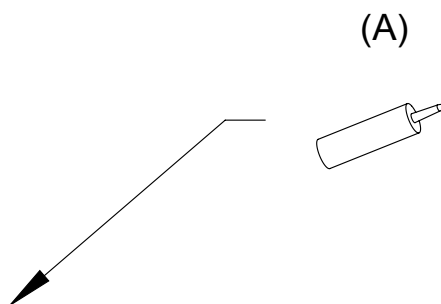

(B) SILICONARE NEL LATO INTERNO
I PROFILI (5) E (6)

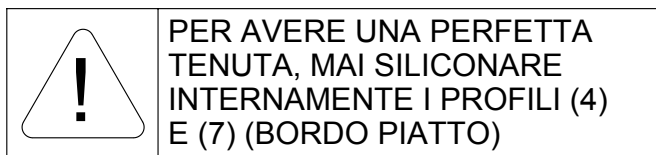

PER AVERE UNA PERFETTA
TENUTA, MAI SILICONARE
INTERNAMENTE I PROFILI (4)
E (7) (BORDO PIATTO)

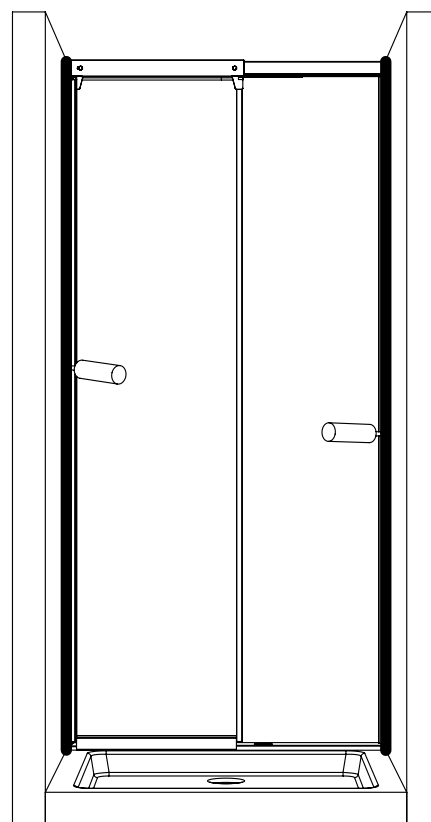
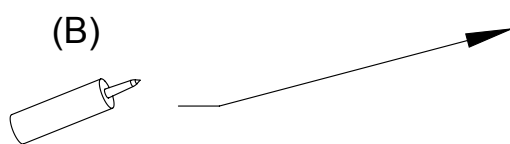

E' consigliabile utilizzare la cabina
trascorso il periodo di asciugatura
indicato dal sigillante utilizzato